

CATALOG

2026



**KOMFORT
FLOW**

AIR DIFFUSER - AIR GRILLE - DAMPER - FILTER & ACCESSORIES

SQUARE CEILING DIFFUSER - MODEL ASD



4-ASD



3-ASD



2-ASD



2C-ASD



1-ASD

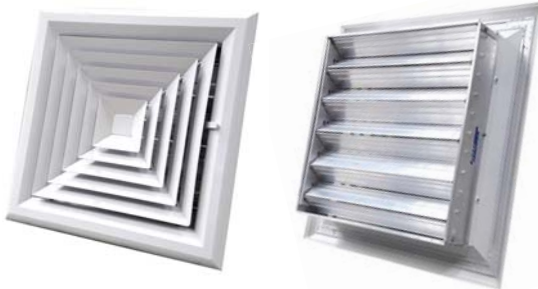

4-ASD (WD)

Square Ceiling Diffuser is 1-4 ways type air diffuser. The number in front of each model indicates the direction of the air flow. The removable core is fixed by spring loaded which can be removed easily by hand without any tool.

Material : Extruded Aluminum
 Finishing : Anodized Aluminum
 Powder Coating
 Optional : Volume Control Damper - (WD)

Section Details

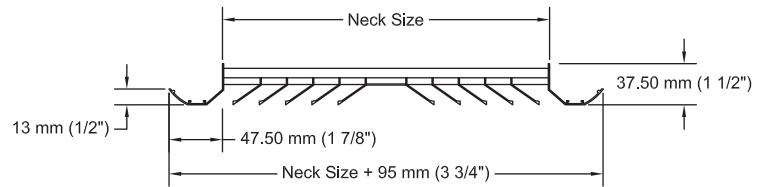

Section : 4-ASD

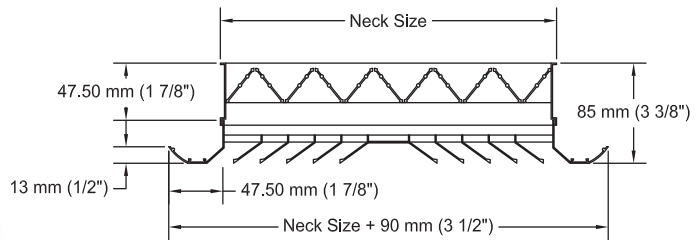

Section : 4-ASD (WD)

Performance Table

Duct Size		Free Area (Sq.Ft.)	Flow Rate (CFM)	NC	Throw (Ft.)
(inch)	(mm)				
6"x6"	150x150	0.20	225	36	4-6
8"x8"	200x200	0.35	356	35	5-9
10"x10"	250x250	0.55	556	37	7-13
12"x12"	300x300	0.79	700	34	6-12
14"x14"	350x350	1.07	953	35	11-16
16"x16"	400x400	1.40	1244	37	14-18
18"x18"	450x450	1.77	1350	34	12-18
20"x20"	500x500	2.18	1677	36	14-20
22"x22"	550x550	2.63	2017	36	14-22
24"x24"	600x600	3.14	2400	37	16-22

Installation

1. Remove the core.
2. Fixing the screw to the hole at the neck.
3. Install the core to the proper position.
4. Optional volume damper can be adjusted by the lever at the front of the diffuser.

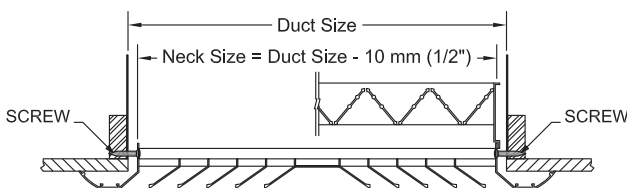

Installation Section

Unit Conversion : CFM = 1.699 CMH = 0.472 L/S
 Ft = 0.305 M
 Sq.Ft. = 0.093 Sq.M.
 FPM = 0.005 m/s

RECTANGULAR CEILING DIFFUSER - MODEL ARD



4L-ARD



4L-ARD



3S-ARD

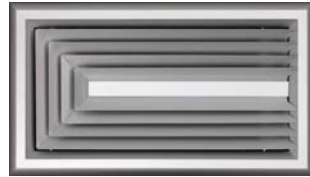

3L-ARD



2S-ARD



2L-ARD



1S-ARD



1L-ARD

Rectangular Ceiling Diffuser is 1-4 ways air diffuser. The number in front of each model indicates the direction of the air flow. The louver blades are arranged along to short (S) or long side (L). The removable core is fixed by spring loaded which can be removed easily by hand without any tool.

Material : Extruded Aluminum
 Finishing : Anodized Aluminum
 Powder Coating
 Optional : Volume Control Damper - (WD)

Section Details

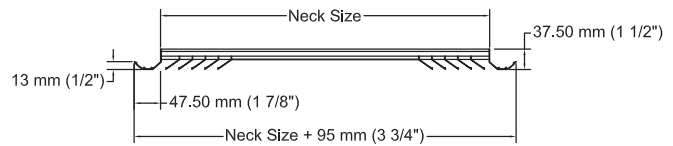

Section : 4L-ARD

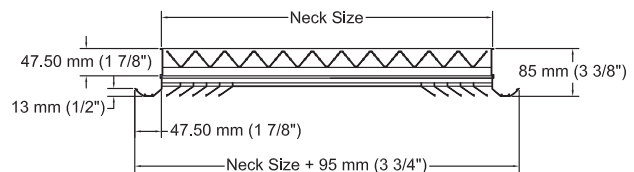

Section : 4L-ARD (WD)

Performance Table

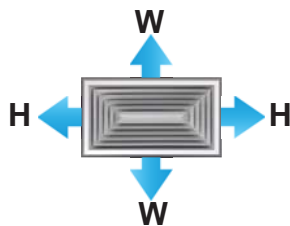

Duct Size		Free Area (Sq.Ft.)	Flow Rate (CFM)	NC	Throw (Ft)	
(inch)	(mm)				W	H
12"x6"	300x150	0.40	450	37	9	7
16"x8"	400x200	0.70	700	34	12	8
20"x10"	500x250	1.10	953	35	14	10
24"x12"	600x300	1.60	1410	38	16	12
28"x14"	700x350	2.15	1677	36	18	15
32"x16"	800x400	2.80	2210	37	22	19

Unit Conversion : CFM = 1.699 CMH = 0.472 L/S
 Ft = 0.305 M
 Sq.Ft. = 0.093 Sq.M.
 FPM = 0.005 m/s

Installation

1. Remove the core.
2. Fixing the screw to the hole at the neck.
3. Install the core to the proper position.
4. Optional volume damper can be adjusted by the lever at the front of the diffuser.

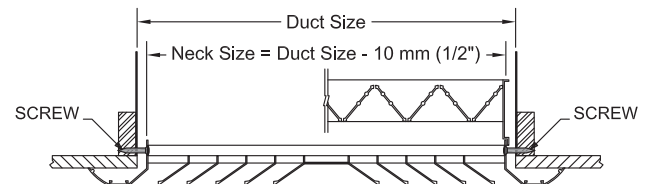

Installation Section

SQUARE CEILING DIFFUSER - MODEL CSD



4-CSD

3-CSD

2-CSD

2C-CSD

1-CSD

Komfortflow Square Ceiling Diffuser Model CSD has inclined neck size in order to provide the maximum flow with low static pressure and low noise, The number in front of each model indicates the direction of the air flow. The removable core is fixed by spring loaded which can be removed easily by hand without any tool.

Material : Extruded Aluminum

Finishing : Anodized Aluminum

Powder Coating

Optional : Volume Control Damper - (WD)

Border Selection

Curve Border (Standard)

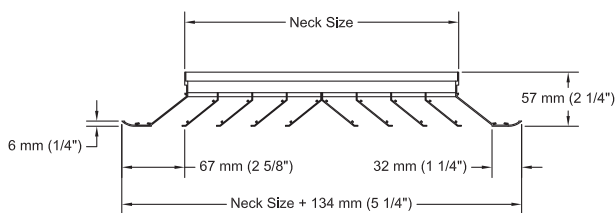

Section : 4-CSD

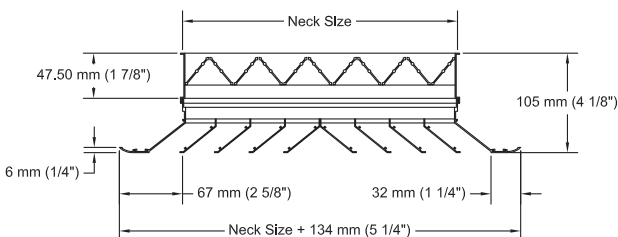

Section : 4-CSD(WD)

High Border

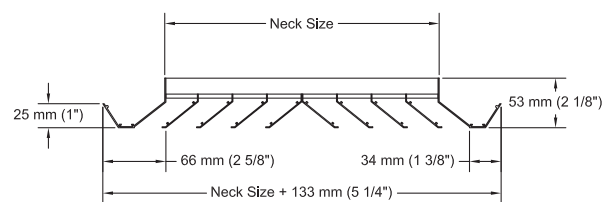

Section : 4-CSD-D

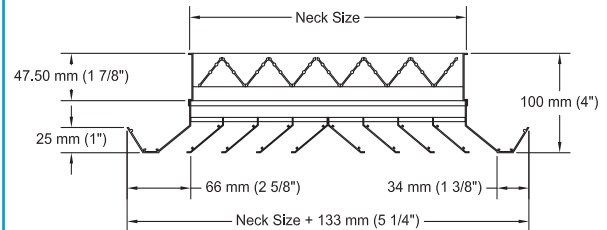

Section : 4-CSD-D(WD)

Flat Border

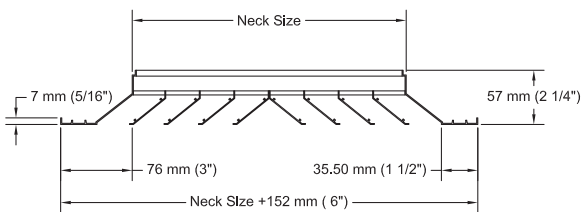

Section : 4-CSD-F

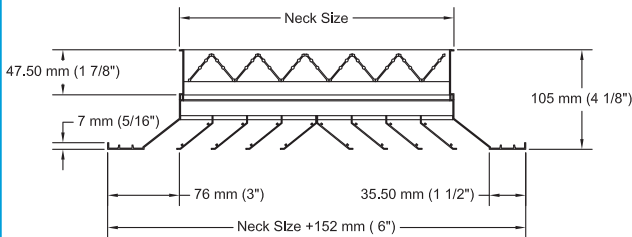

Section : 4-CSD-F(WD)

Flat Border - TBAR

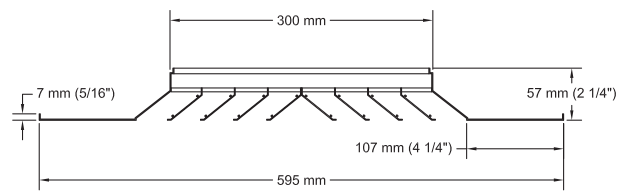

Section : 4-CSD-F (Lay-in TBAR)

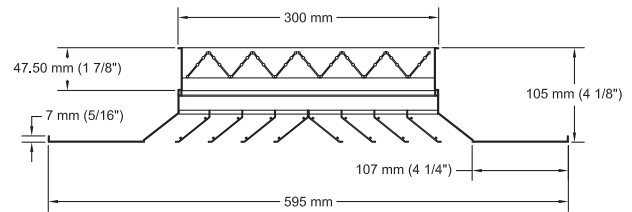

Section : 4-CSD-F(WD) (Lay-in TBAR)

Installation on regular Ceiling

1. Remove the core.
2. Fixing the screw to the hole at the neck.
3. Install the core to the proper position.
4. Optional volume damper can be adjusted by the lever at the front of the diffuser.

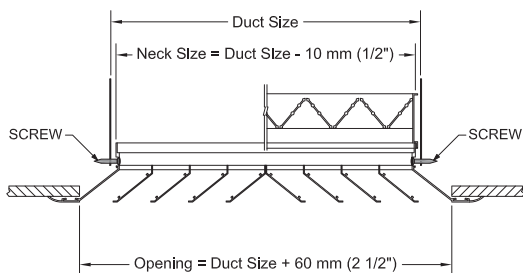

Installation Section for regular ceiling

Installation on TBAR Ceiling

1. Lay-in on the TBAR ceiling.
2. Border size should be reduced by 5 mm. from the ceiling grid size.
Example : Ceiling grid size is 600x600 mm.
Grille border size shall be 595x595 mm.

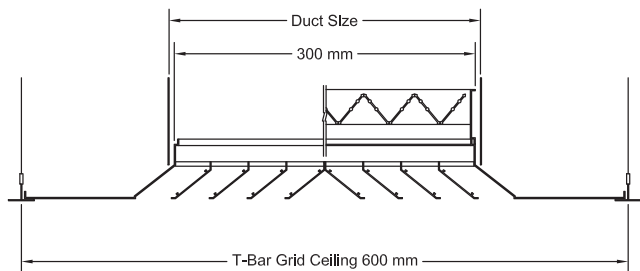

Installation Section for regular ceiling

SQUARE CEILING DIFFUSER - MODEL CSD



4-CSD

3-CSD

2-CSD

2C-CSD

1-CSD

Komfortflow Square Ceiling Diffuser Model CSD has inclined neck size in order to provide the maximum flow with low static pressure and low noise, The number in front of each model indicates the direction of the air flow. The removable core is fixed by spring loaded which can be removed easily by hand without any tool.

Material : Extruded Aluminum

Finishing : Anodized Aluminum

Powder Coating

Optional : Volume Control Damper - (WD)

Border Selection

Curve Border (Standard)

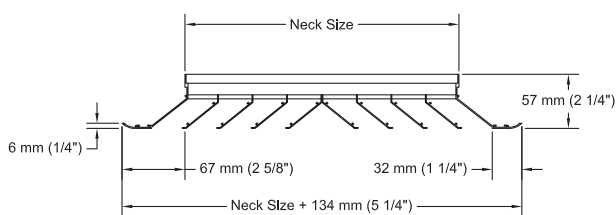

Section : 4-CSD

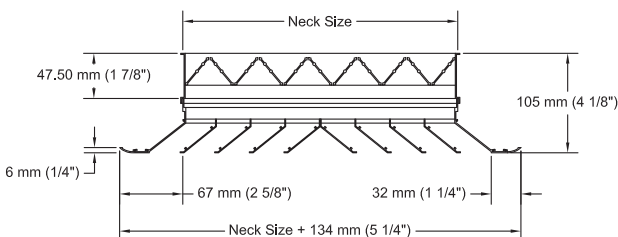

Section : 4-CSD(WD)

Curve Border (Flat Plate)

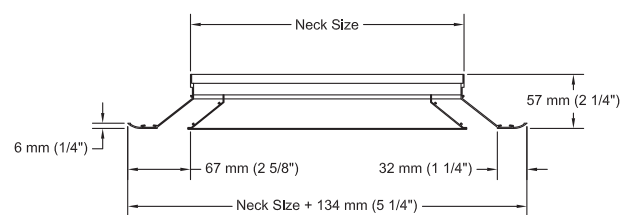

Section : 4-CSD Flat Plate

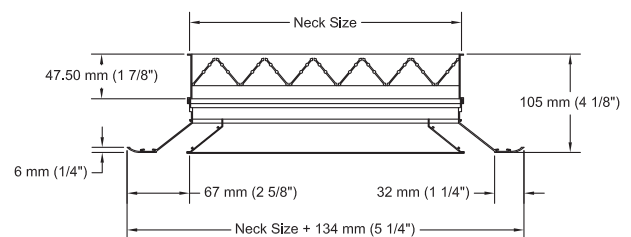

Section : 4-CSD-Flate Palte (WD)

RECTANGULAR CEILING DIFFUSER - MODEL CRD

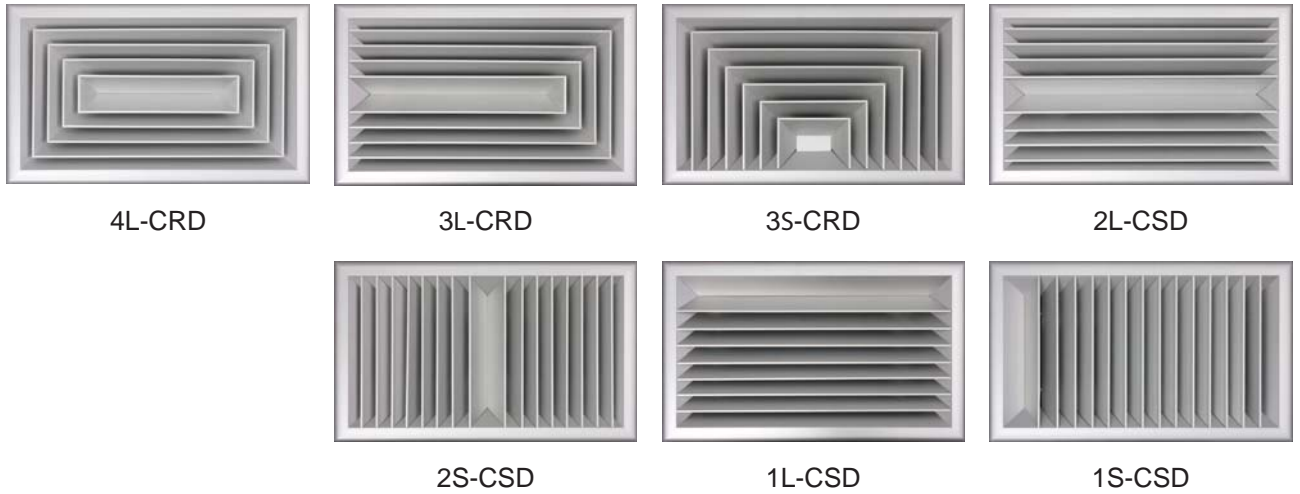

Komfortflow Rectangular Ceiling Diffuser Model CRD has inclined neck size in order to provide the maximum flow with low static pressure and low noise, The number in front of each model indicates the direction of the air flow. The removable core is fixed by spring loaded which can be removed easily by hand without any tool.

- Material : Extruded Aluminum
- Finishing : Anodized Aluminum
Powder Coating
- Optional : Volume Control Damper - (WD)

Border Selection

Curve Border (Standard)



Model : 4L-CRD

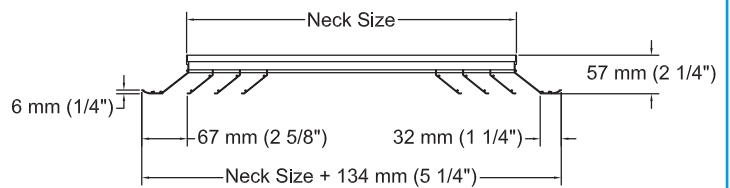

Section : 4L-CRD

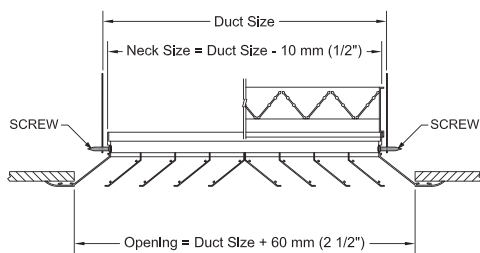

Installation : 4L-CRD / 4L-CRD(WD)

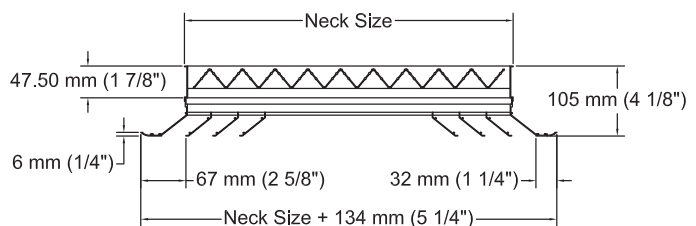

Section : 4L-CRD(WD)

High Border



Section : 4L-CRD-D

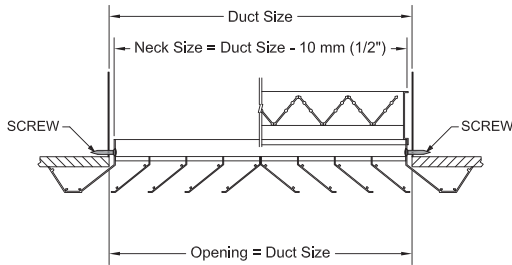

Installation : 4L-CRD-D / 4L-CRD-D(WD)

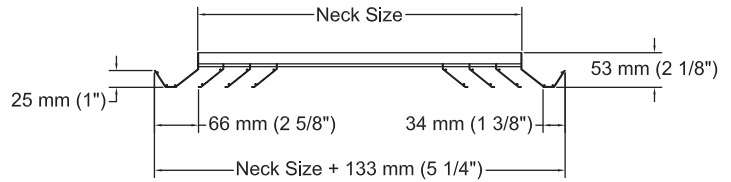

Section : 4L-CRD-D

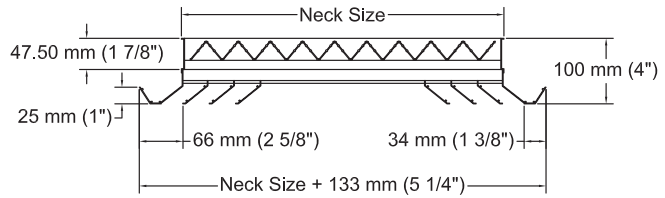

Section : 4L-CRD-D(WD)

Flat Border



Section : 4L-CRD-F

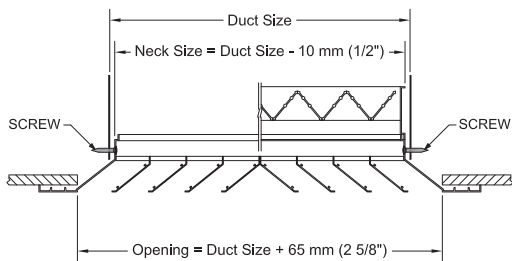

Installation : 4L-CRD-F / 4L-CRD-F(WD)

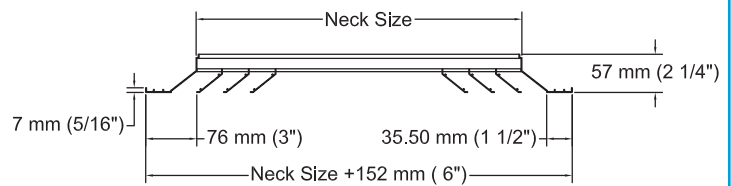

Section : 4L-CRD-F

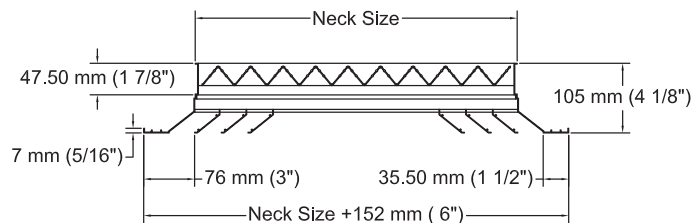

Section : 4L-CRD-F(WD)

PERFORMANCE DATA - MODEL CSD / CRD

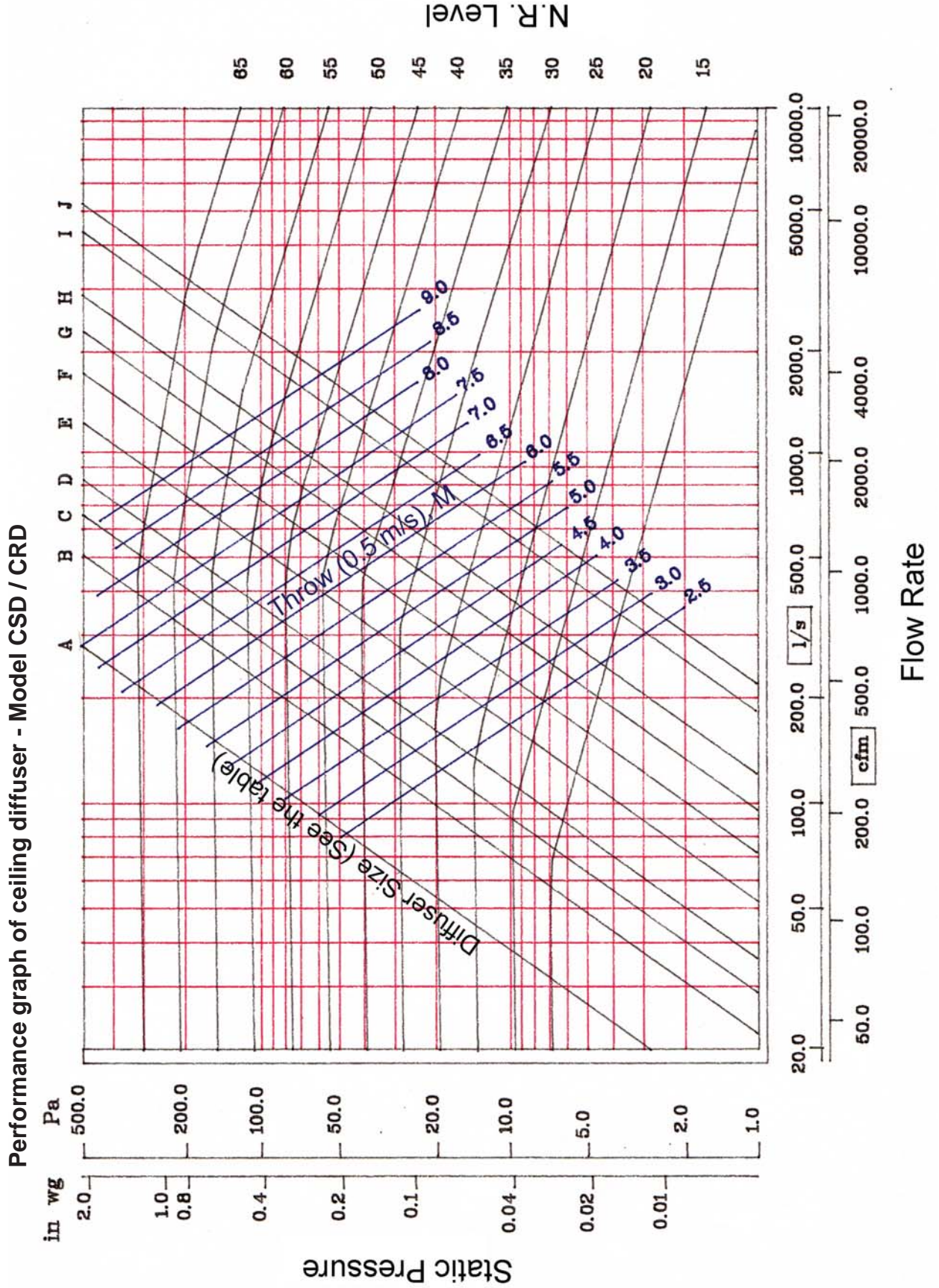

PERFORMANCE DATA - MODEL CSD / CRD

Key for the performance graph of Model CSD / CRD

Diffuser	Nominal Size		Neck Size	
	(inch)	(mm)	(inch)	(mm)
A	6 x 6	150 x 150	5.5 x 5.5	140 x 140
B	8 x 8	200 x 200	7.5 x 7.5	190 x 190
C	9 x 9	225 x 225	8.8 x 8.8	215 x 215
D	10 x 10	250 x 250	9.5 x 9.5	240 x 240
E	12 x 12	300 x 300	11.5 x 11.5	290 x 290
F	14 x 14	350 x 350	13.5 x 13.5	340 x 340
G	16 x 16	400 x 400	15.5 x 15.5	390 x 390
H	18 x 18	450 x 450	17.5 x 17.5	440 x 440
I	22 x 22	550 x 550	21.5 x 21.5	490 x 490
J	24 x 24	600 x 600	23.5 x 23.5	590 x 590

Performance Table @ NC 35 for Model 4-CSD

Duct Size		Free Area (Sq.Ft.)	Flow Rate (CFM)	NC	Throw @ 100 FPM	
(inch)	(mm)				(Ft)	(M)
6"x6"	150x150	0.20	159	35	6.6	2.0
8"x8"	200x200	0.36	297	35	11.2	3.4
10"x10"	250x250	0.56	530	35	14.8	4.5
12"x12"	300x300	0.80	742	35	17.4	5.3
14"x14"	350x350	1.09	953	35	19.7	6.0
16"x16"	400x400	1.42	1,271	35	20.5	6.3
18"x18"	450x450	1.80	1,483	35	21.7	6.6
20"x20"	500x500	2.22	1,801	35	22.6	6.9
22"x22"	550x550	2.69	2,076	35	23.6	7.2
24"x24"	600x600	3.20	2,331	35	24.3	7.4

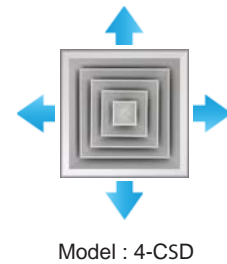

Model : 4-CSD

Performance Table @ NC 35 for Model 4L-CRD

Duct Size		Free Area (Sq.Ft.)	Flow Rate (CFM)	NC	Throw (Ft) @ 100 FPM		Throw (M) @ 100 FPM	
(inch)	(mm)				W	H	W	H
12"x6"	300x150	0.41	356	35	13.1	6.6	4.0	2.0
16"x8"	400x200	0.73	680	35	20.7	11.2	6.3	3.4
20"x10"	500x250	1.14	1,002	35	21.0	14.8	6.4	4.5
24"x12"	600x300	1.64	1,394	35	22.6	17.4	6.9	5.3
28"x14"	700x350	2.23	1,808	35	23.3	19.7	7.1	6.0
32"x16"	1200x600	2.92	2,192	35	23.6	20.7	7.2	6.3

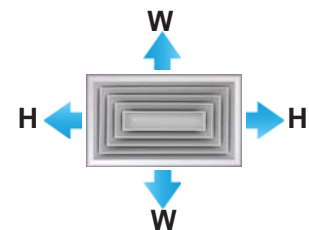

Model : 4L-CRD

Unit Conversion : CFM = 1.699 CMH = 0.472 L/S
 Ft = 0.305 M
 Sq.Ft. = 0.093 Sq.M.
 FPM = 0.005 m/s

ADJUSTABLE CEILING DIFFUSER - MODEL ADCD

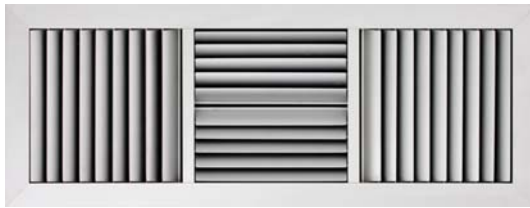

4-ADCD



3-ADCD

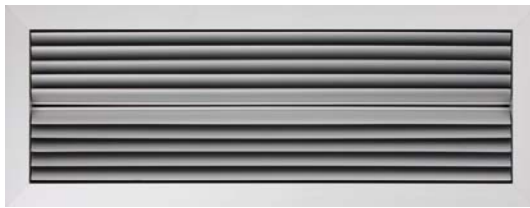

2-ADCD

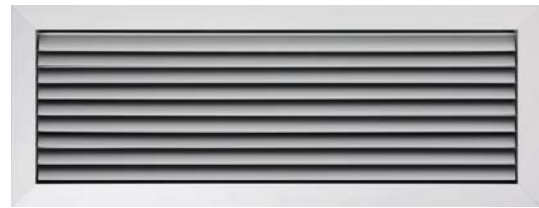

1-ADCD

Komfort Flow ADCD Model is the adjustable ceiling air diffuser. It is used for direct supply air precisely to suit the desired application. Blades can be arranged to one to four air flow direction. Each blade is manually adjusted. The shape of the diffuser is available in square or rectangular.

Material : Extruded Aluminum

Finishing : Anodized Aluminum

Powder Coating

Optional : Volume Control Damper - (WD)

Blade Arrangement



Square Diffuser

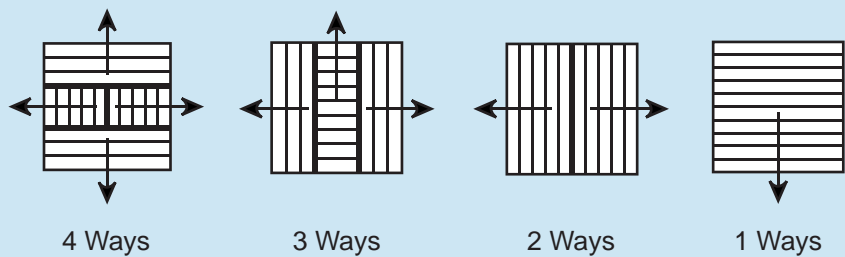

Rectangular Diffuser

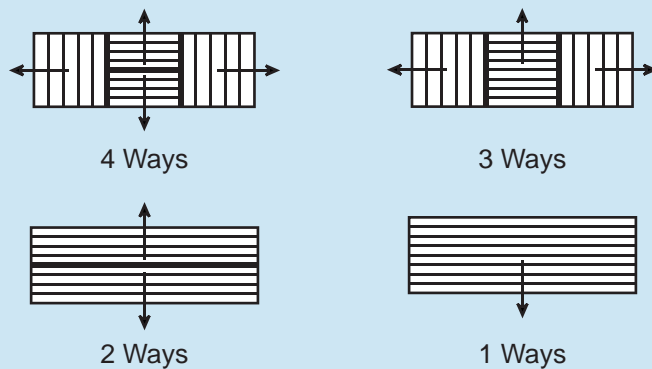

Border Selection & Section Details



Curve Border - Model ADCD



Flat Border - Model ADCD-F

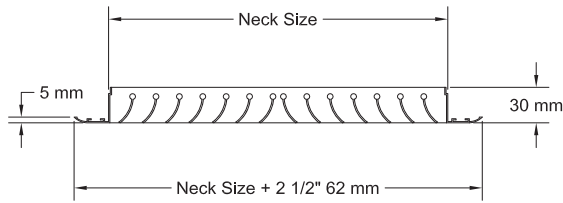

Section Model : ADCD

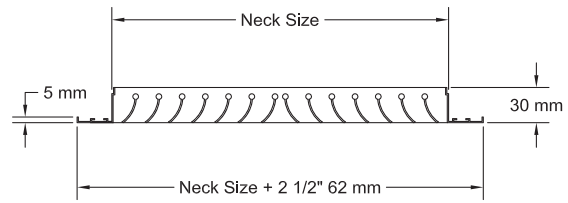

Section Model : ADCD-F

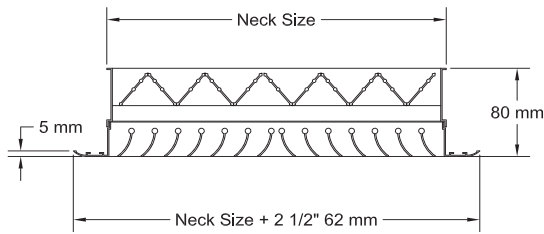

Section Model : ADCD(WD)

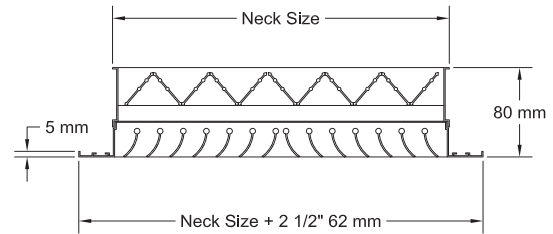

Section Model : ADCD-F(WD)

Installation Details

1. Standard Installation
Fixing screw at the front frame

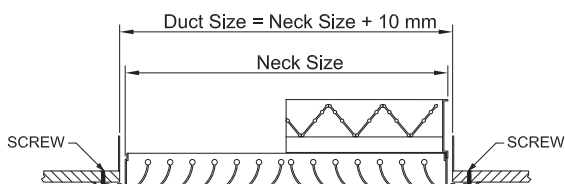

2. Hidden Screw Installation
Fixing screw at the back support.
(Require the additional support in the plenum)

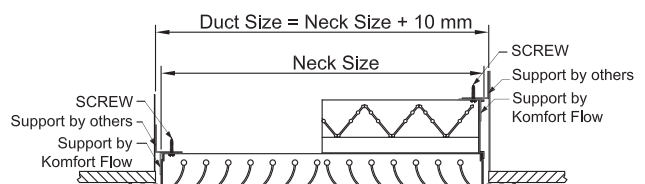

PERFORMANCE DATA

Square Adjustable Ceiling Diffuser - Model ADCD

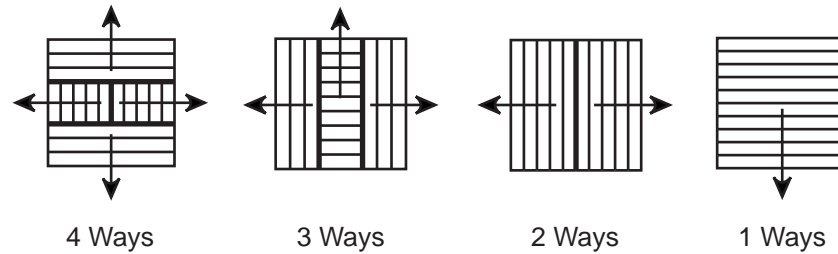

Nominal Size		Flow Rate	Static Pressure	NC	Throw @ 100 FPM (0.5 m/s)							
					4 Ways		3 Ways		2 Ways		1 Ways	
in	mm	CFM	in.wg.		Ft.	M	Ft.	M	Ft.	M	Ft.	M
6 x 6	150 x 150	167	0.203	35	16	4.8	17	5.1	19	5.7	22	6.7
8 x 8	200 x 200	257	0.158	35	17	5.1	17	5.2	19	5.8	23	7.0
10 x 10	250 x 250	392	0.121	35	17	5.1	18	5.4	19	5.8	23	7.1
12 x 12	300 x 300	550	0.121	35	18	5.4	19	5.8	21	6.4	26	7.8
14 x 14	350 x 350	792	0.121	35	19	5.8	21	6.4	23	7.1	27	8.3
16 x 16	400 x 400	817	0.086	35	17	5.2	19	5.8	21	6.4	24	7.4
18 x 18	450 x 450	1,120	0.086	35	19	5.8	20	6.1	22	6.8	27	8.1
20 x 20	500 x 500	1,430	0.086	35	20	6.1	22	6.7	25	7.5	29	8.7
22 x 22	550 x 550	1,683	0.086	35	20	6.2	22	6.8	25	7.7	30	9.0
24 x 24	600 x 600	1,800	0.073	35	21	6.4	22	6.7	24	7.3	29	8.8

Unit Conversion : CFM = 1.699 CMH = 0.472 L/S
 Ft = 0.305 M
 Sq.Ft. = 0.093 Sq.M.
 FPM = 0.005 m/s

PERFORMANCE DATA

Rectangular Adjustable Ceiling Diffuser - Model ADCD

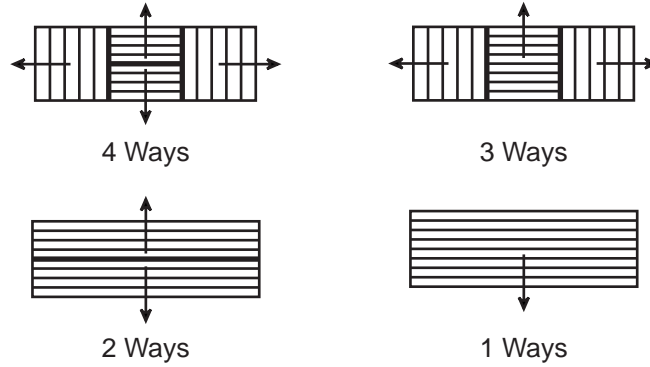

Nominal Size		Flow Rate	Static Pressure	NC	Throw @ 100 FPM (0.5 m/s)							
					4 Ways		3 Ways		2 Ways		1 Ways	
in	mm	CFM	in.wg.		Ft.	M	Ft.	M	Ft.	M	Ft.	M
12 x 6	300 x 150	293	0.158	35	17	5.1	18	5.4	20	6.0	23	7.1
16 x 8	400 x 200	512	0.125	35	17	5.2	19	5.8	20	6.1	25	7.6
20 x 10	500 x 250	792	0.121	35	19	5.8	21	6.4	23	7.1	27	8.3
24 x 12	600 x 300	970	0.086	35	18	5.5	19	5.9	22	6.7	26	7.8
24 x 18	600 x 450	1,430	0.086	35	20	6.1	22	6.7	25	7.5	29	8.7
24 x 20	600 x 500	1,683	0.086	35	20	6.2	22	6.8	25	7.7	30	9.0
30 x 18	750 x 450	1,800	0.073	35	21	6.4	22	6.7	24	7.3	29	8.8
36 x 18	900 x 450	2,000	0.073	35	21	6.4	22	6.7	25	7.6	29	8.8
36 x 20	900 x 500	2,047	0.055	35	19	5.9	21	6.3	23	6.9	27	8.2

Unit Conversion : CFM = 1.699 CMH = 0.472 L/S
 Ft = 0.305 M
 Sq.Ft. = 0.093 Sq.M.
 FPM = 0.005 m/s

ROUND CEILING DIFFUSER - MODEL RD



Model : RD

Komfort Flow round ceiling diffuser model RD has the excellent 360 degree horizontal air flow pattern makes it ideal for the high volume air flow application such as the department store, the hotel lobby or the exposed duct application. Komfort Flow RD model consists of several cones suspended below the ceiling line by an outer cones. The core can be removed for service.

Material : Cold form aluminum sheet
 Finishing : Powder coating
 Optional : Volume control butterfly damper - (WD)
 Available size : 6", 8", 10", 12", 14", 16", 18", 20"

Dimension Data

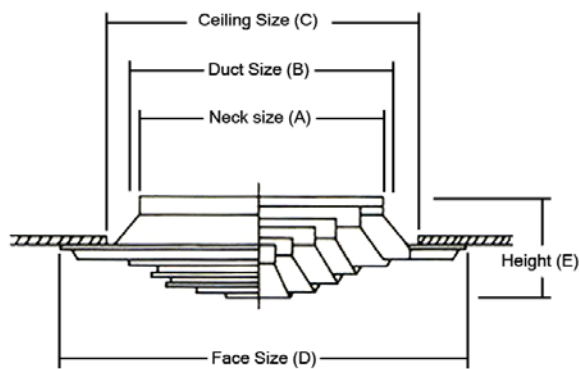

Model	Neck Size	Duct Size	Opening size	Face Size	Height
	A	B	C	D	E
RD 6	6"	6 1/2"	9 5/8"	12 5/8"	2 5/8"
	153	165	245	321	67
RD 8	8 1/8"	8 5/8"	11 3/4"	14 3/4"	3 1/8"
	207	219	299	375	79
RD 10	10 1/8"	10 5/8"	13 3/4"	16 3/4"	3 1/8"
	257	270	349	426	79
RD 12	12 1/8"	12 5/8"	16"	19"	3 1/4"
	308	321	407	483	83
RD 14	14 1/8"	14 5/8"	17 1/8"	21 1/8"	3 1/2"
	359	371	435	537	89
RD 16	16 1/8"	16 5/8"	19 1/8"	23 1/8"	3 1/2"
	410	422	486	587	89
RD 18	18 1/8"	18 5/8"	21 1/8"	25 1/8"	4"
	460	473	537	638	102
RD 20	20 1/8"	20 5/8"	23 1/2"	29 1/2"	4 3/8"
	511	524	597	749	111

Section Details

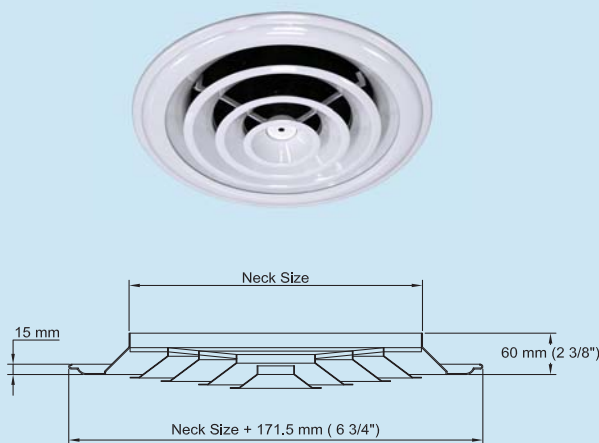

Section : RD

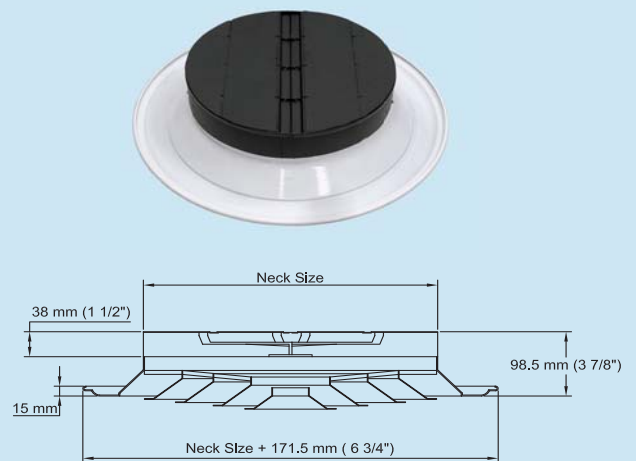

Section : RD(WD)

Section Details

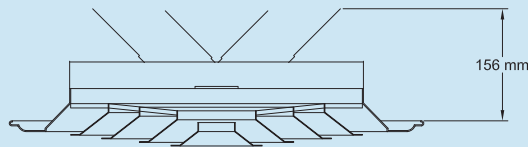
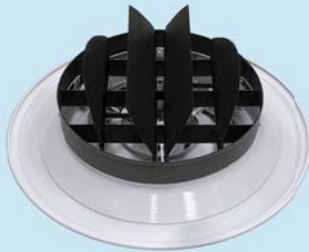

Section : RD(WD) : Damper Opened

Installation

1. Remove the core.
2. Fixing the screw to the hole at the neck.
3. Install the core to the proper position.
4. Optional volume damper can be adjusted thru the hole at the front of the diffuser.

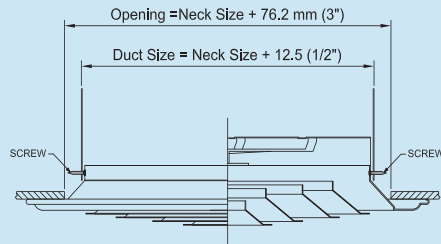

Installation Section

Performance Data

Norm. Size (in)	Neck Area (Sq.Ft.)	Neck Velocity (FPM)	400	500	600	700	800	900	1000	1100	1200
6"	0.196	Flow Rate (CFM)	78	98	117	137	157	176	196	215	235
		Static Pressure (in.wg.)	0.03	0.04	0.05	0.08	0.09	0.12	0.14	0.17	0.21
		NC	-	-	15	20	24	27	31	34	36
		Throw (Ft.)	3-5	3-5	3-6	3-6	3-7	3-8	4-8	4-8	5-9
8"	0.349	Flow Rate (CFM)	140	175	210	245	280	315	350	385	420
		Static Pressure (in.wg.)	0.05	0.05	0.07	0.1	0.12	0.16	0.18	0.22	0.25
		NC	-	-	16	21	26	29	32	35	38
		Throw (Ft.)	3-5	3-6	3-7	4-7	4-8	4-9	5-10	5-10	6-12
10"	0.545	Flow Rate (CFM)	218	276	327	382	436	490	545	600	654
		Static Pressure (in.wg.)	0.05	0.06	0.08	0.1	0.14	0.17	0.2	0.24	0.27
		NC	-	-	17	22	27	30	33	36	39
		Throw (Ft.)	3-6	4-8	4-8	4-9	4-9	4-10	5-10	5-12	6-12
12"	0.785	Flow Rate (CFM)	314	395	470	550	630	705	785	865	940
		Static Pressure (in.wg.)	0.06	0.06	0.09	0.12	0.16	0.19	0.25	0.3	0.38
		NC	-	-	18	23	27	31	34	38	40
		Throw (Ft.)	5-11	6-14	7-14	8-15	8-16	8-17	9-18	9-19	10-20
14"	1.07	Flow Rate (CFM)	428	535	642	749	856	963	1070	1177	1284
		Static Pressure (in.wg.)	0.06	0.07	0.1	0.13	0.16	0.2	0.26	0.31	0.38
		NC	-	13	19	24	28	32	35	38	41
		Throw (Ft.)	7-15	7-15	8-17	9-19	10-22	10-22	12-24	12-26	12-26
16"	1.396	Flow Rate (CFM)	558	698	838	977	1117	1256	1396	1537	1675
		Static Pressure (in.wg.)	0.07	0.08	0.12	0.14	0.17	0.21	0.27	0.32	0.39
		NC	-	14	19	25	29	32	36	39	41
		Throw (Ft.)	8-15	8-15	8-18	10-19	10-22	10-24	12-25	12-28	12-28
18"	1.766	Flow Rate (CFM)	706	883	1060	1235	1413	1589	1766	1943	2119
		Static Pressure (in.wg.)	0.09	0.1	0.14	0.15	0.18	0.22	0.28	0.33	0.4
		NC	-	15	20	26	30	33	36	39	42
		Throw (Ft.)	8-15	8-16	8-18	10-20	10-22	12-24	12-24	14-30	14-30
20"	2.18	Flow Rate (CFM)	872	1090	1308	1526	1744	1962	2180	2398	2616
		Static Pressure (in.wg.)	0.11	0.13	0.15	0.17	0.21	0.26	0.31	0.36	0.42
		NC	-	15	21	26	30	34	37	40	43
		Throw (Ft.)	8-16	8-18	8-18	10-22	10-22	12-24	14-30	16-32	16-32

Unit Conversion : CFM = 1.699 CMH = 0.472 L/S
Sq.Ft. = 0.093 Sq.M.

Ft = 0.305 M
FPM = 0.005 m/s

4-WAY PERFORATED CEILING DIFFUSER : MODEL 4-PFR



Model : 4-PFR

Komfort Flow 4-way perforated ceiling diffuser, model 4-PFR is designed for the T-BAR ceiling application. The inside fixed blade makes 4 ways air flow pattern and the front perforated face diffuses the air flow to the desired area.

Material : Housing made from aluminum
Perforated face - steel (Standard)
- aluminum (on request)
Finishing : Powder coating
Optional : Volume control butterfly damper - (WD)

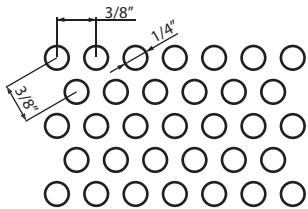

Perforated Pattern
Dia. 1/4" (6.4 mm) & Pitch 3/8" (9.5 mm)



Push the spring lock to remove the perforated face



Remoable Face

Section & Installation Details

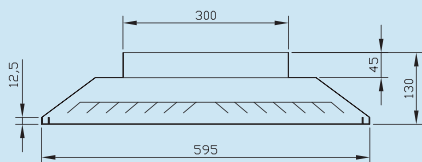

Section : 4-PFR

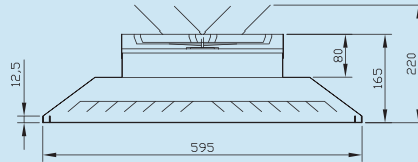

Section : 4-PFR(WD)

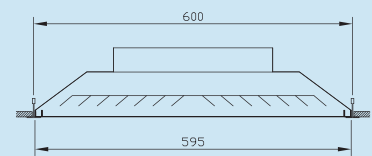

Installation : 4-PFR

Performace Data

Neck Velocity	FPM	300	400	500	600	700	800	1000	1200	1400
Velocity Pressure	in.wg.	0.006	0.01	0.016	0.022	0.031	0.04	0.062	0.09	0.122
Air Flow	CFM	236	314	393	471	550	628	785	942	1100
Total Pressure	in.wg.	0.023	0.041	0.064	0.093	0.126	0.165	0.258	0.371	0.505
NC (Noise Criteria)		-	15	22	28	33	37	45	51	56
Throw	Ft.	6	8	10	12	14	15	16	18	19

Unit Conversion : CFM = 1.699 CMH = 0.472 L/S
Sq.Ft. = 0.093 Sq.M.

Ft = 0.305 M
FPM = 0.005 m/s

FLAT PLATE T-BAR CEILING DIFFUSER : MODEL FPD



Model : FPD



Model : FPD(WD)

Komfort Flow flat plate ceiling diffuser, model FPD is the square diffuser which has been specially designed to provide the unobstructive appearance required for architectural excellence and the 360 degree diffusion pattern at the minimum noise level.

Material : Housing and flat face constructed from aluminum sheet. All borders are folded for the solid construction.

Finishing : Powder coating

Optional : Volume control butterfly damper - (WD)

Model FPD are composed of removable flat palte face. By using snap-in pin. It's easy to remove for cleaning or maintenance.

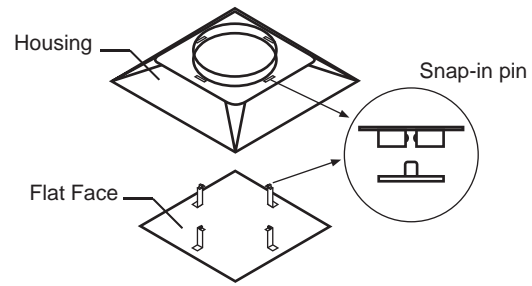

Section & Installation Details

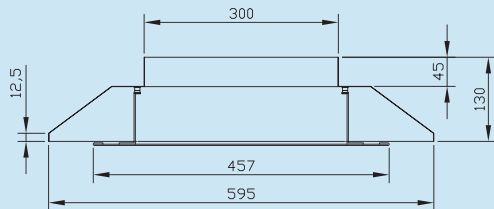

Section : FPD

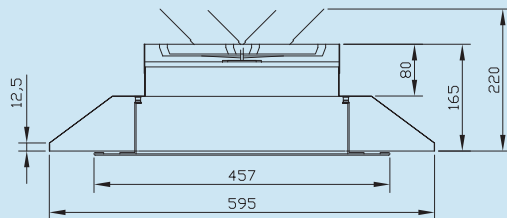

Section : FPD(WD)

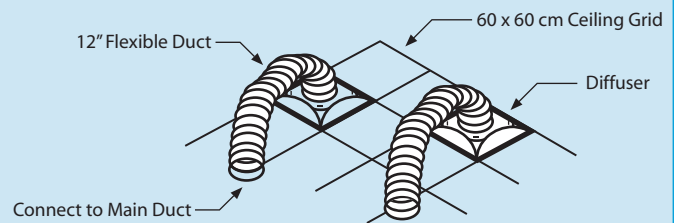

Installation : FPD

Performace Data

Neck Velocity	FPM	400	500	600	700	800	900	1000	1200	1400
Velocity Pressure	in.wg.	0.010	0.016	0.022	0.031	0.040	0.050	0.062	0.090	0.122
Air Flow	CFM	314	393	471	550	628	707	785	942	1099
Total Pressure	in.wg.	0.050	0.080	0.114	0.155	0.204	0.258	0.318	0.458	0.622
NC (Noise Criteria)		-	-	14	18	25	28	31	37	43
Throw	Ft.	7	10	11	13	14	15	17	18	20

Unit Conversion : CFM = 1.699 CMH = 0.472 L/S
Sq.Ft. = 0.093 Sq.M.

Ft = 0.305 M
FPM = 0.005 m/s

SWIRL CEILING DIFFUSER - MODEL SWD



Model : SWD



Model : SWD(WD)

Komfort Flow swirl diffuser, model SWD is designed to provide optimum mixing of conditioned supply air with that of space, thereby minimizing draft temperatures and velocities within the occupied or process levels. Their unique design enables them to create room air induction ratios significantly greater than those of conventional diffusers.

- Material : Frame made from extruded aluminum
Swirl face made from aluminum sheet
- Finishing : Powder coating
- Optional : Opposed blade volume damper - (WD)

Fixed blade swirl diffusers produce a horizontal radial air pattern with high induction effect, making them ideally suited for application with high heating and cooling differentials.

Section Details

Standard Curve Border Section

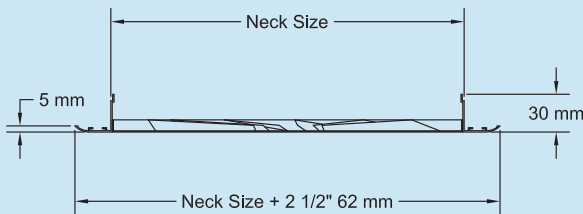

Section : SWD

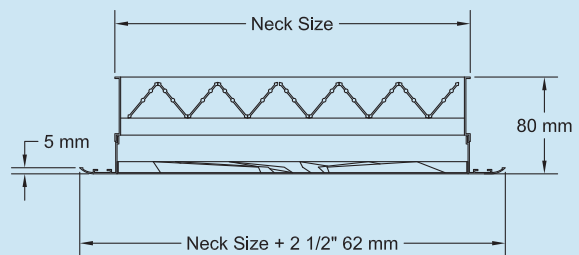

Section : SWD(WD)

Flat Border Section

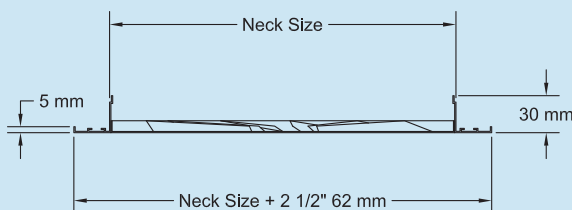

Section : SWD-F

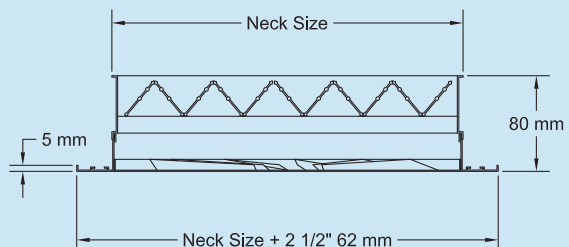

Section : SWD-F(WD)

Flat Border



Model : SWD-F



Model : SWD-F(WD)

Performance Data

SIZE	Neck Velocity	FPM	200	300	400	500	600	700	800	900	1000
5 x 5	Air Flow	CFM	27	41	54	68	82	95	109	122	136
	Total Pressure	in.wg.	0.011	0.024	0.046	0.067	0.097	0.132	0.172	0.218	0.269
	NC		<15	<15	<15	20	24	29	33	38	42
	Throw (FT)	Ft.	1-1-1	1-1-1	1-1-2	1-1-2	1-1-3	1-2-3	1-2-4	1-2-4	1-2-4
6 x 6	Air Flow	CFM	39	59	79	99	118	138	158	177	197
	Total Pressure	in.wg.	0.009	0.021	0.037	0.058	0.083	0.113	0.148	0.187	0.231
	NC		<15	<15	<15	17	21	24	27	31	34
	Throw (FT)	Ft.	1-1-1	1-1-1	1-1-2	1-1-2	1-1-3	1-2-3	1-2-4	1-2-4	2-2-5
8 x 8	Air Flow	CFM	70	105	140	175	210	245	280	315	350
	Total Pressure	in.wg.	0.014	0.031	0.054	0.085	0.123	0.167	0.218	0.276	0.34
	NC		<15	16	19	21	24	27	30	32	35
	Throw (FT)	Ft.	1-1-1	1-1-1	1-1-3	1-2-3	1-2-4	2-2-5	2-3-6	2-3-6	2-3-7
10 x 10	Air Flow	CFM	109	164	218	273	327	382	436	491	545
	Total Pressure	in.wg.	0.015	0.033	0.059	0.092	0.132	0.18	0.235	0.297	0.367
	NC		<15	<15	18	22	26	30	35	39	43
	Throw (FT)	Ft.	1-1-1	1-1-1	1-2-3	1-2-4	2-3-5	2-3-6	2-3-7	3-4-8	3-4-8
12 x 12	Air Flow	CFM	157	236	314	393	471	550	628	707	785
	Total Pressure	in.wg.	0.012	0.028	0.049	0.077	0.111	0.151	0.197	0.249	0.308
	NC		<15	<15	<15	20	24	29	33	38	42
	Throw (FT)	Ft.	1-1-1	1-1-1	2-2-5	2-3-6	2-4-7	3-4-8	3-5-10	4-5-11	4-6-12
14 x 14	Air Flow	CFM	214	320	427	534	641	748	855	962	1068
	Total Pressure	in.wg.	0.016	0.035	0.062	0.098	0.141	0.191	0.249	0.315	0.390
	NC		<15	<15	18	24	31	35	41	45	50
	Throw (FT)	Ft.	1-1-1	1-1-1	2-3-6	2-3-6	2-4-7	3-5-8	4-5-10	4-6-12	4-7-13
16 x 16	Air Flow	CFM	280	420	560	700	840	980	1120	1260	1400
	Total Pressure	in.wg.	0.019	0.042	0.075	0.118	0.17	0.231	0.301	0.381	0.471
	NC		<15	<15	21	28	35	42	49	56	63
	Throw (FT)	Ft.	1-1-1	1-1-1	2-3-6	2-4-7	3-4-8	3-5-10	4-6-11	4-6-13	5-7-14
24 x 24	Air Flow	CFM	628	942	1256	1570	1884	2198	2512	2826	3140
	Total Pressure	in.wg.	0.023	0.053	0.094	0.138	0.199	0.271	0.354	0.448	0.554
	NC		9	18	24	30	38	48	52	58	66
	Throw (FT)	Ft.	2-3-5	3-4-8	4-5-10	5-6-11	5-8-13	6-9-14	7-10-15	8-11-15	9-12-16

Unit Conversion : CFM = 1.699 CMH = 0.472 L/S
Sq.Ft. = 0.093 Sq.M.

Ft = 0.305 M
FPM = 0.005 m/s

LINEAR SLOT DIFFUSER

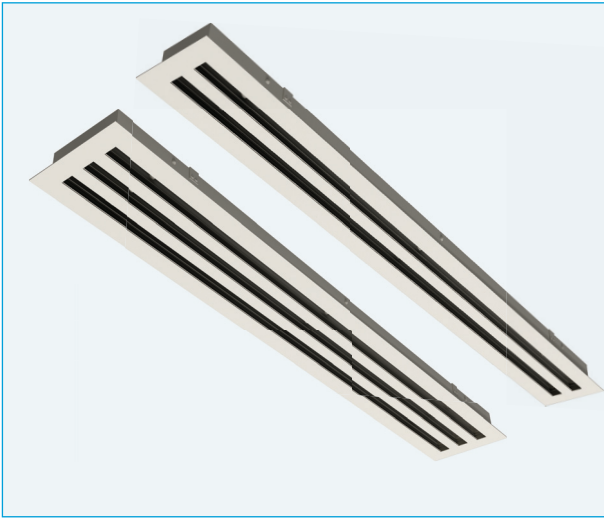

Komfort Flow Linear Slot Diffuser is designed to supply a high air change rate capacity to the large area such as the office plan, hotel lobby, showroom, corridor, etc. Linear slot diffusers are also suitable for any architecture or interior design and can be installed either the ceiling or the sidewall applications.

Material : High quality extruded aluminum

Slot width : Standard 3/4"(19 mm.) wide
Others size available upon request

Finishing : Anodized Aluminum
Powder Coating

Frame Selection

The standard frame is 29 mm. and the other frame types are available to allow the slot diffuser to be fully integrated with the ceiling design.

Standard Frame

3 mm. Edge Frame

20 mm. Frame

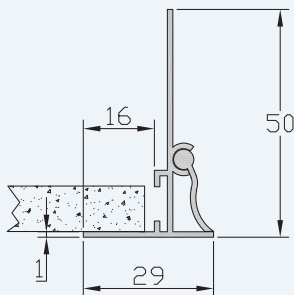
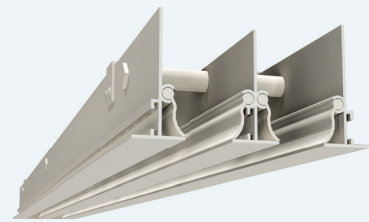
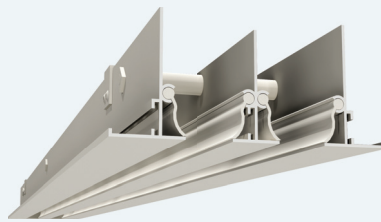
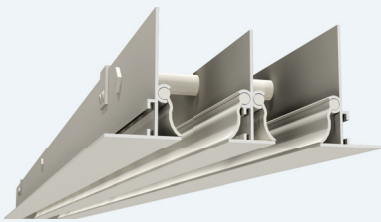

Standard Frame Section

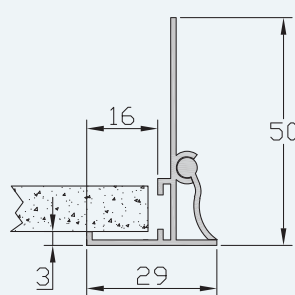

3 mm. Edge Frame Section

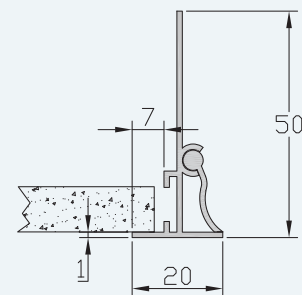

20mm. Frame Section

Air Flow adjusted Pattern

Air pattern can be changed vertically or horizontally by the inside deflection blades. These blades can be fully adjusted from the front face.

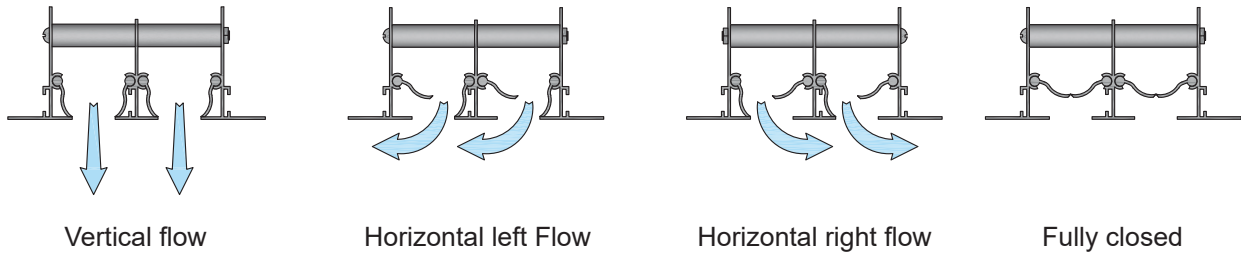

Dimension of linear slot diffuser

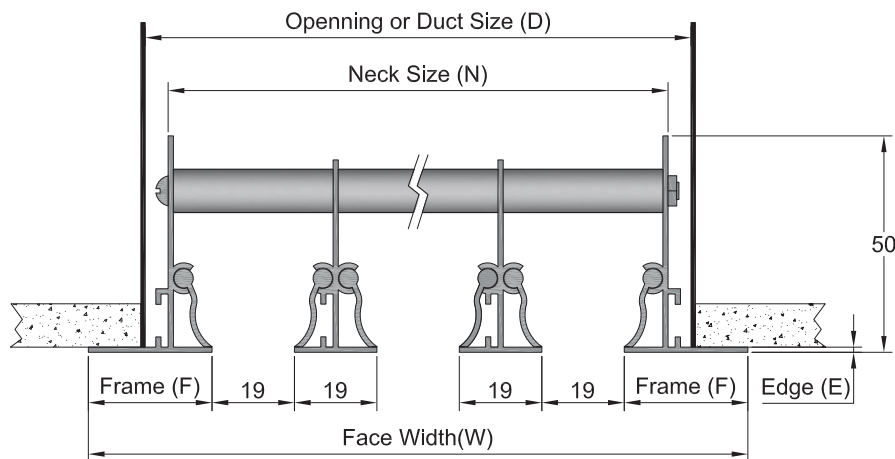

No. of Slot	Opening Size	Neck Size	Standard Frame			3mm. Edge Frame			20mm Frame		
	D	N	W	F	E	W	F	E	W	F	E
1-SLOT	49	39	76	29	1	76	29	3	59	20	1
2-SLOT	87	77	114	29	1	114	29	3	97	20	1
3-SLOT	126	116	152	29	1	152	29	3	135	20	1
4-SLOT	164	154	190	29	1	190	29	3	173	20	1
5-SLOT	202	192	229	29	1	229	29	3	211	20	1
6-SLOT	240	230	267	29	1	267	29	3	250	20	1
7-SLOT	278	268	305	29	1	305	29	3	288	20	1
8-SLOT	316	306	343	29	1	343	29	3	326	20	1

Unit : mm

Section Details - Standard Frame

Model 1-LSD

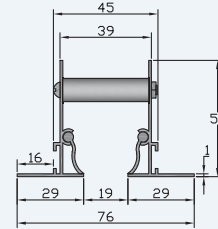
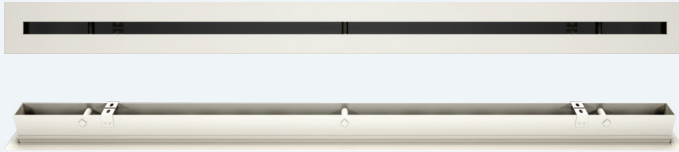

Model 2-LSD

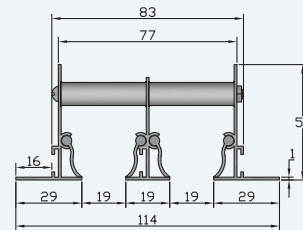
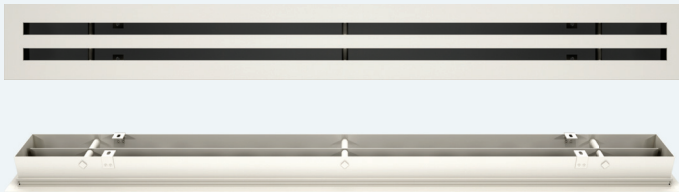

Model 3-LSD

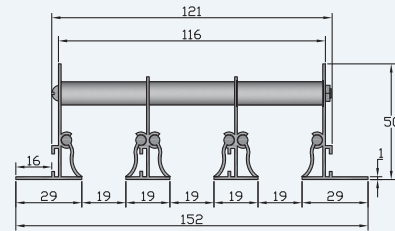
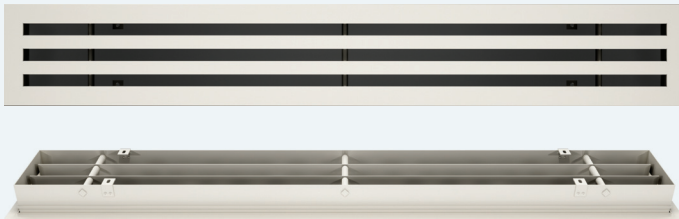

Model 4-LSD

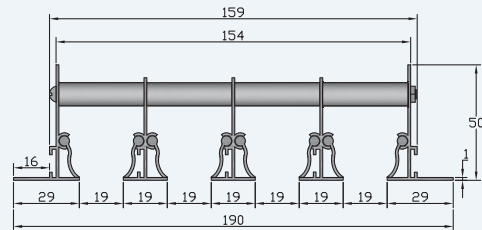
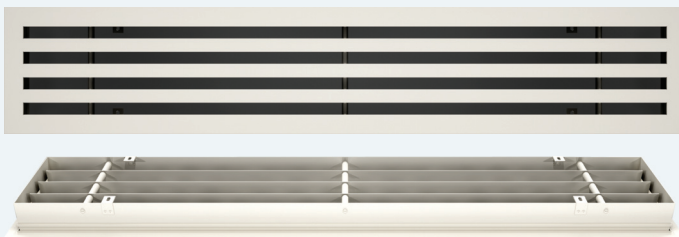

Model 5-LSD

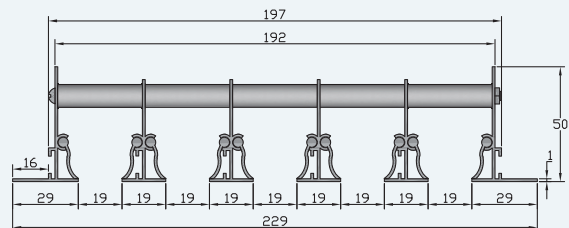
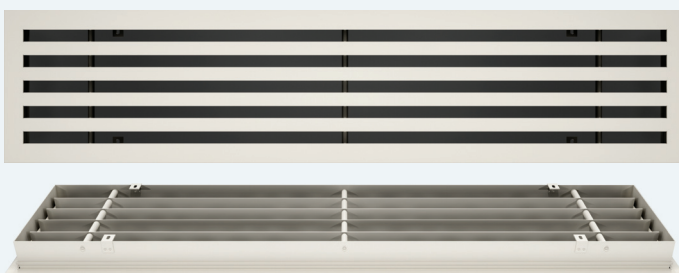

Section Details - Standard Frame

Model 6-LSD

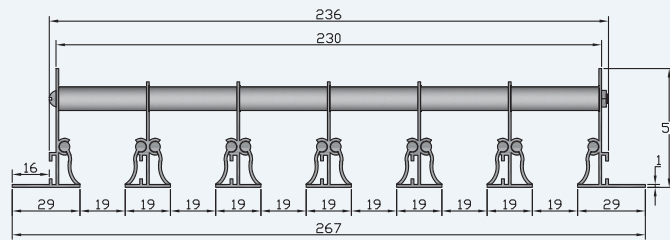
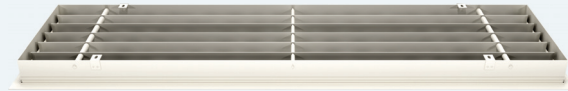

Model 7-LSD

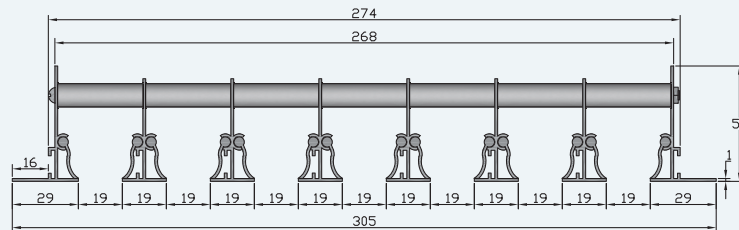
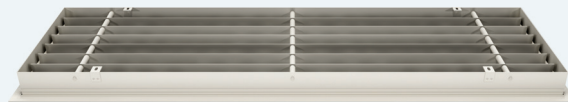

Model 8-LSD

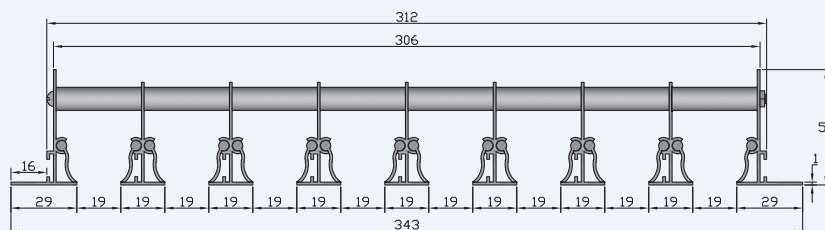
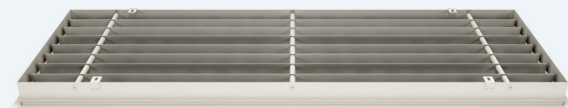
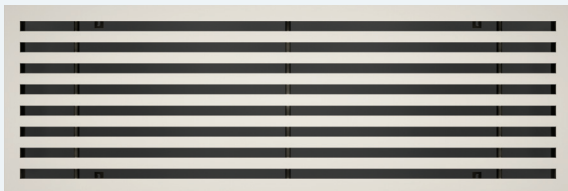

Section Details - 3mm. Edge Frame

Model 1-LSD

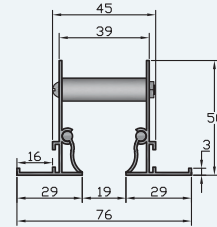
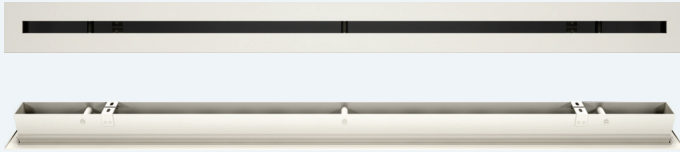

Model 2-LSD

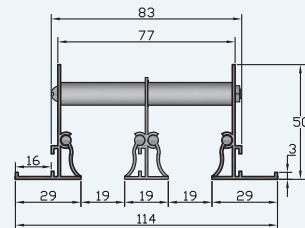
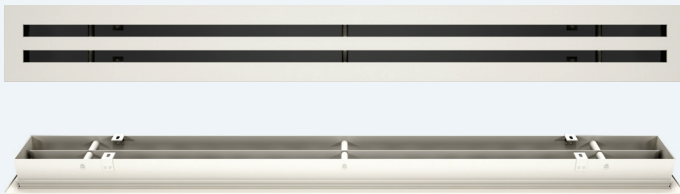

Model 3-LSD

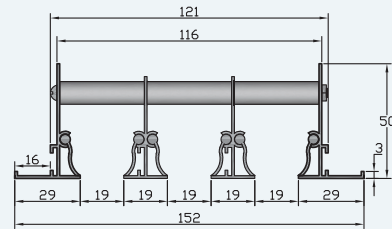
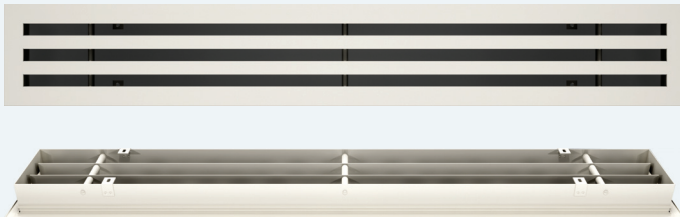

Model 4-LSD

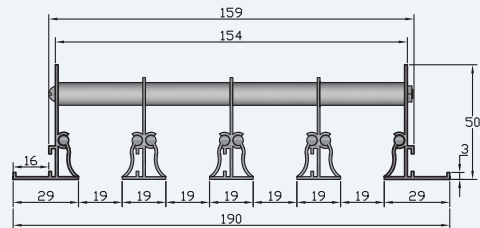
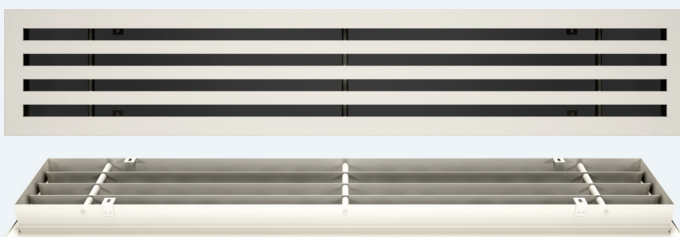

Model 5-LSD

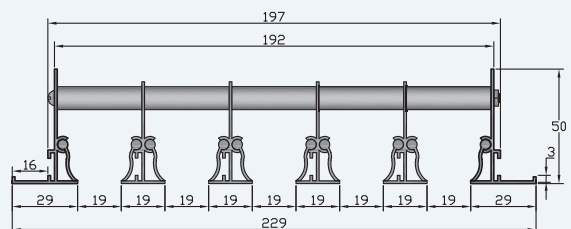
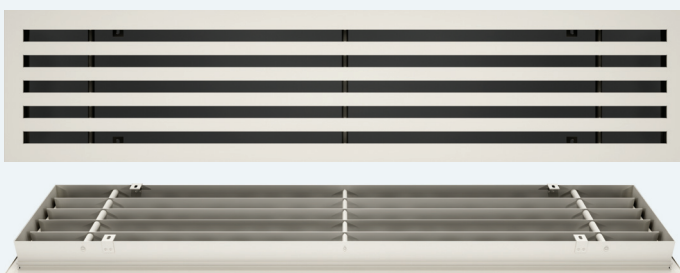

Section Details - 20 mm. Frame

Model 1-LSD

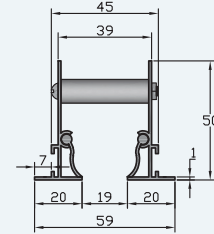
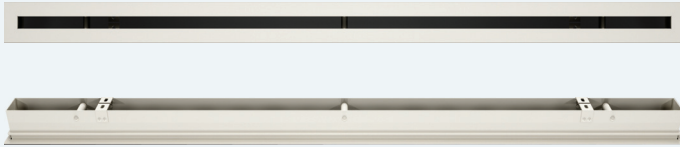

Model 2-LSD

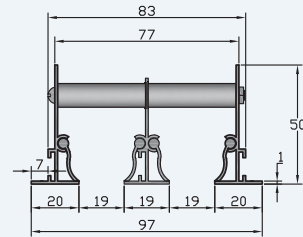
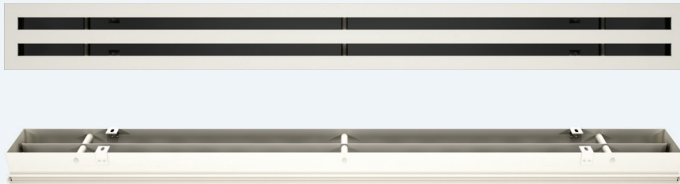

Model 3-LSD

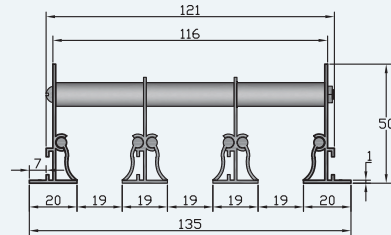
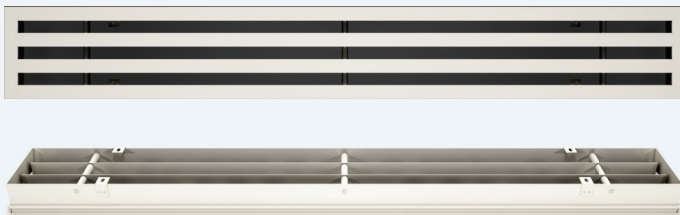

Model 4-LSD

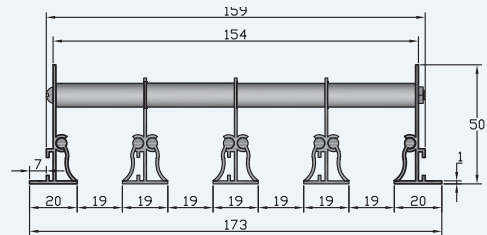
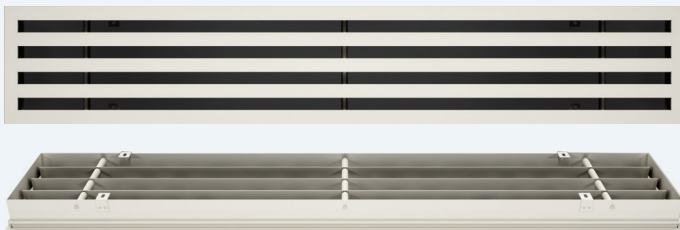

Model 5-LSD

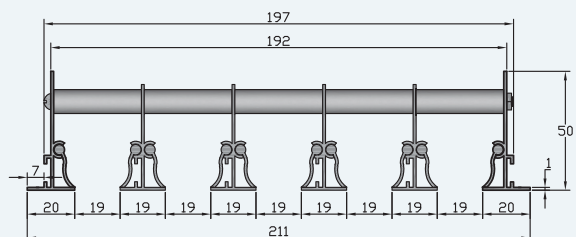
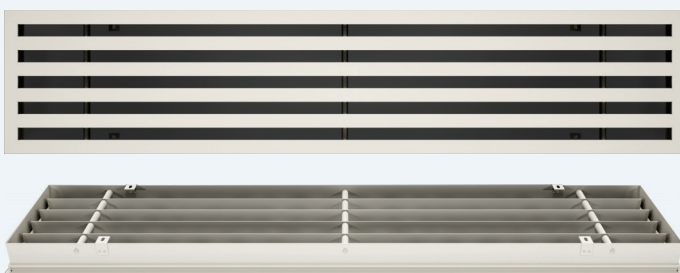

Section Details - 20 mm Frame

Model 6-LSD

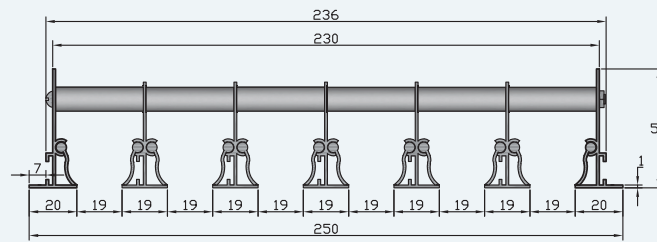

Model 7-LSD

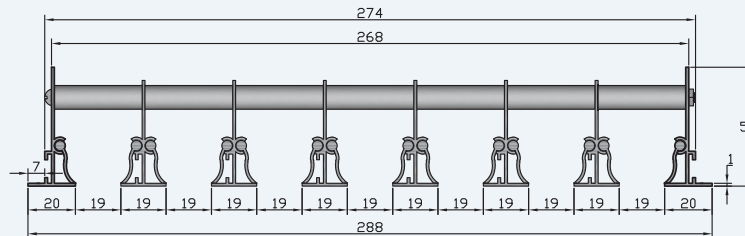

Model 8-LSD

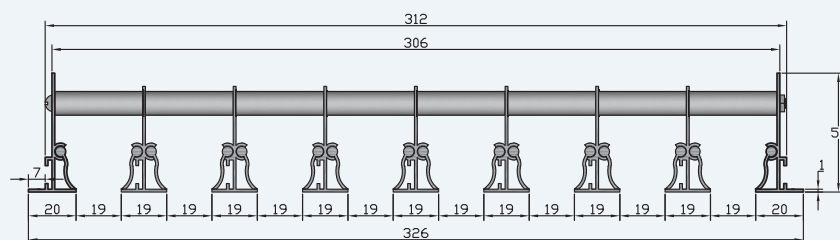
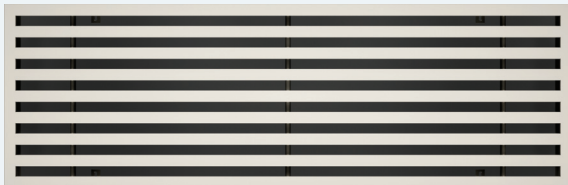

Multiple Section

Connecting Joint



2 pieces connected



3 or more pieces connected



Ceiling corner connection



Side wall corner connection

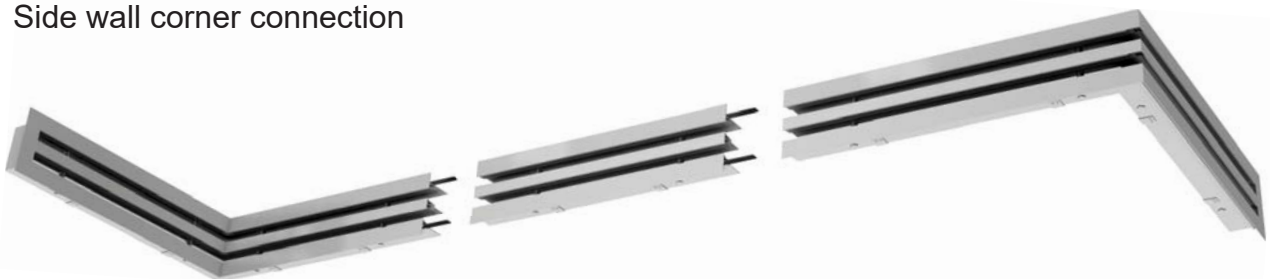

Performance Data

NO. OF SLOT	CFM PER FT	20	30	40	60	80	100	125	150	200	250	300
1	VEL	320	480	640	960	1280	1600					
	SP	0.016	0.038	0.06	0.1	0.142	0.394					
	NC	-	-	-	10	15	35					
	THROW	5	10	15	20	22	35					
2	VEL		240	320	480	640	800	1000	1200	1600		
	SP		0.009	0.017	0.04	0.065	0.113	0.176	0.27	0.4		
	NC		-	-	-	5	12	15	25	35		
	THROW		4	7	11	20	24	30	35	41		
3	VEL			213	320	427	533	667	800	1066	1333	
	SP			0.009	0.018	0.036	0.06	0.085	0.15	0.221	0.35	
	NC			-	-	5	10	15	20	30	35	
	THROW			6	9	15	20	24	30	34	42	
4	VEL				240	320	400	500	600	800	1000	1200
	SP				0.014	0.023	0.04	0.06	0.095	0.14	0.242	0.32
	NC				-	-	-	10	25	30	35	40
	THROW				10	14	18	20	26	30	38	46
5	VEL					256	320	400	480	640	800	960
	SP					0.014	0.018	0.04	0.058	0.098	0.156	0.24
	NC					-	-	-	10	20	30	35
	THROW					12	16	20	24	28	36	42

Remarks

VEL : Flow Velocity (FPM)
 SP : Static Pressure (in.wg.)
 THROW : Air throw (ft.)

Linear Bar Grilles **Model : LBG**

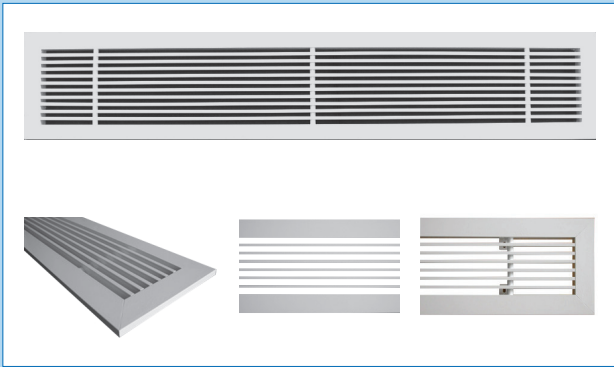

Fig.1 shows Model LBG with 30 mm. standard border

Product Features

Komfort Flow Four Way Linear Bar Grilles are available for air distribution, return air and architectural application.

LBG Model is recommended for ceiling and floor application.

Ceiling Application

LBG is normally installed in the public area such as Lobby and Corridor.

Floor Application

LBG can be installed in computer room and access floor.

Material & Finishing

Komfort Flow Linear Bar Grilles are built with high grade and heavy duty aluminum construction finishing with the powder coating in white. Core bar are supplied parallel to the long dimension. The custom color is upon request.

Available Cores and Frames

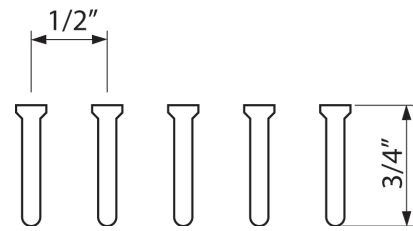

Fig.2 shows "0 Degree Deflection"

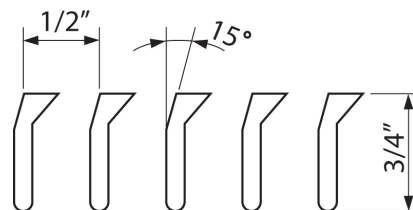

Fig.3 shows "15 Degree Deflection"

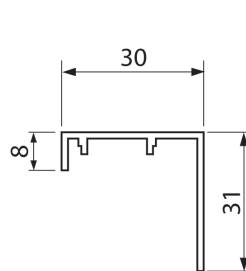

Fig.4 CeilingFrame

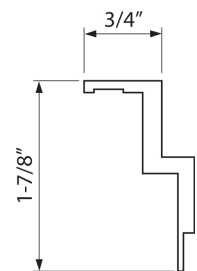

Fig.5 Floor Frame

Ceiling Frame

- Flat frame with 30 mm. border face
- Recommend for general application

Floor Frame

- Very thick extruded aluminum.
- Recommend for floor application

Corner Module

Corner module are available for all series of linear bar grilles. All modules are constructed from extruded aluminum. The standard module are shown below.

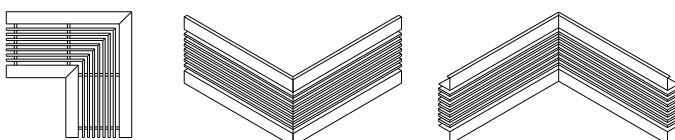

Corner

Wall Inside

Wall Outside

Installation Details

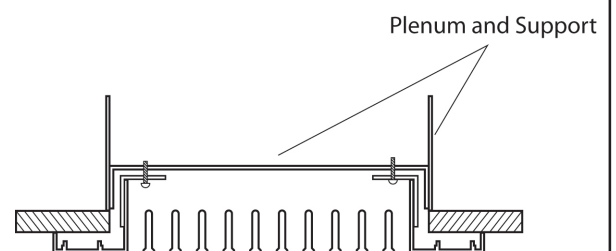

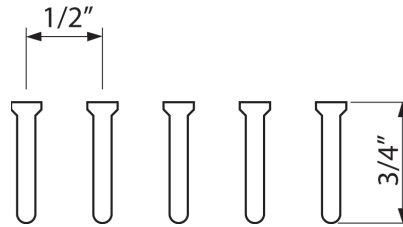

0 Degree Deflection

Size	Static Pressure (in.wg.)	0.01	0.022	0.04	0.063	0.089	0.121	0.159	0.202	0.25
1 1/2"	Flow CFM/Ft.	12	18	24	30	36	42	48	54	60
	NC	-	-	-	-	18	24	28	31	34
	Throw (ft.) C - F	1-4	2-7	4-9	7-12	9-13	11-16	12-17	14-19	16-21
2"	Flow CFM/Ft.	20	29	39	49	59	69	79	89	98
	NC	-	-	-	-	21	25	29	33	36
	Throw (ft.) C - F	1-5	4-9	7-11	9-14	11-16	14-19	16-21	17-22	19-25
3"	Flow CFM/Ft.	38	57	76	95	113	132	151	170	190
	NC	-	-	-	20	25	30	33	36	40
	Throw (ft.) C - F	2-7	7-11	10-14	13-17	16-21	19-24	22-27	24-31	26-34
4"	Flow CFM/Ft.	54	81	108	135	162	189	216	243	270
	NC	-	-	-	21	26	31	34	38	41
	Throw (ft.) C - F	3-8	9-13	13-17	16-21	20-25	23-28	25-30	28-35	31-38
5"	Flow CFM/Ft.	72	108	144	180	216	252	289	324	360
	NC	-	-	17	23	28	33	37	40	43
	Throw (ft.) C - F	4-10	10-14	15-19	18-22	22-27	25-31	27-33	30-37	34-41
6"	Flow CFM/Ft.	90	135	180	225	270	314	360	404	450
	NC	-	-	17	24	30	34	38	41	45
	Throw (ft.) C - F	5-11	10-16	15-20	19-24	23-29	25-33	29-35	31-40	36-44

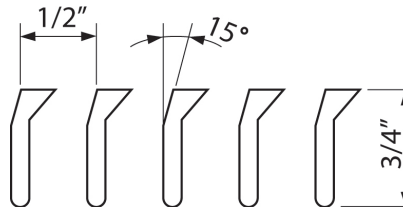

15 Degree Deflection

Size	Static Pressure (in.wg.)	0.01	0.026	0.048	0.076	0.107	0.145	0.191	0.242	0.3
1 1/2"	Flow CFM/Ft.	13	19	26	32	39	45	51	58	64
	NC	-	-	19	25	31	36	40	43	46
	Throw (ft.) C - F	1-4	3-7	5-10	7-12	9-14	11-16	13-18	15-20	16-22
2"	Flow CFM/Ft.	19	29	39	48	58	67	77	87	96
	NC	-	-	16	23	29	33	37	41	44
	Throw (ft.) C - F	1-5	4-8	7-11	9-14	12-17	14-19	16-22	18-23	19-25
3"	Flow CFM/Ft.	34	51	68	85	102	119	136	152	170
	NC	-	-	16	23	29	34	38	41	45
	Throw (ft.) C - F	2-6	6-10	10-14	13-17	16-20	19-24	21-27	24-30	25-33
4"	Flow CFM/Ft.	50	75	100	125	150	175	200	225	250
	NC	-	-	19	25	31	35	40	44	47
	Throw (ft.) C - F	3-8	9-13	13-17	16-20	20-24	22-28	25-30	27-35	30-37
5"	Flow CFM/Ft.	66	99	132	165	198	231	264	297	330
	NC	-	-	20	27	33	38	42	46	48
	Throw (ft.) C - F	4-11	10-15	14-18	18-22	21-29	24-30	27-32	30-35	32-38
6"	Flow CFM/Ft.	84	126	168	210	252	294	336	378	420
	NC	-	-	22	29	35	40	43	47	50
	Throw (ft.) C - F	5-12	10-16	15-21	19-24	23-28	25-31	28-34	31-37	35-41

C = Ceiling , F = Floor

SINGLE DEFLECTION SUPPLY AIR GRILLE - MODEL 2-WSG

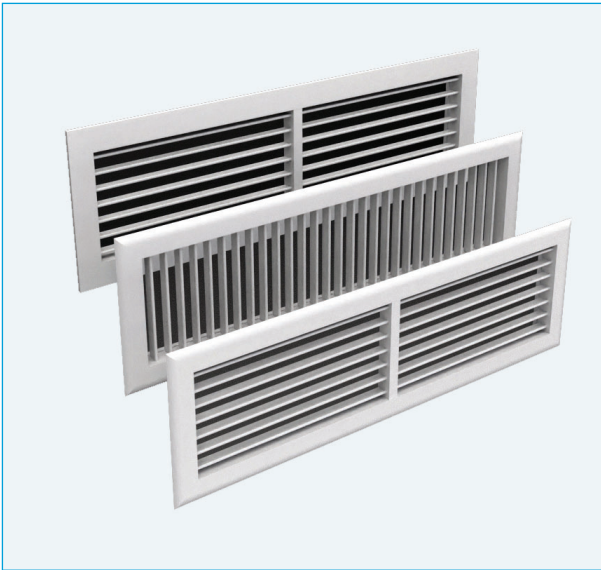

Komfort Flow air grilles and registers are constructed from extruded aluminum comprising with 1 sets of the adjustable blades which can be adjusted to 2 ways air patterns. The blades can be arrange to horizontal blades (Model 2-WSG-H) or vertical blades (Model 2-WSG-V).

Nylon boots fixed between blades and frame that can prevent the click sound and also keep the blades remained at the set position. (Powder coating model, spring wire will be used instead of the boots.)

Optional opposed blade volume control damper can be installed to any type of supply grilles and registers.

The available frame sizes are 12.7 mm (1/2"), 20 mm, 25.4 mm (1"), and 31 mm. (1 1/4").

Blade Arrangement



Model : 2-WSG-V
Vertical front blade



Model : 2-WSG-H
Horizontal front blade

Frame Selection

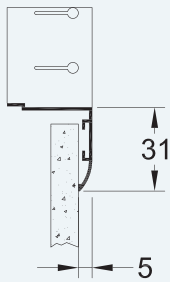

Standard Curve Frame
31 mm. (1 1/4")

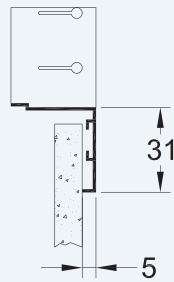

Flat Frame
31 mm. (1 1/4")

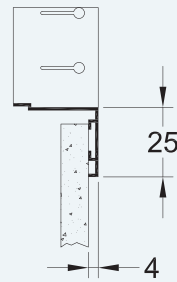

Flat Frame
25 mm (1")

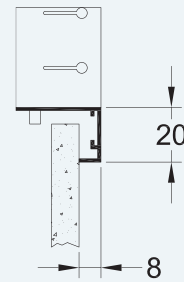

Flat Frame
20 mm

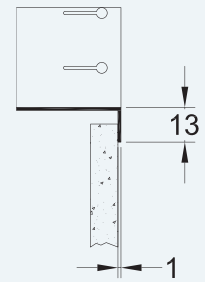

Flat Frame
13 mm (1/2")

Standard Curve Frame 31 mm

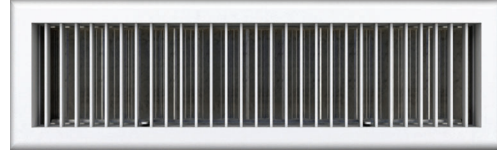

Model : 2-WSG-V

Model : 2-WSG-V(WD)

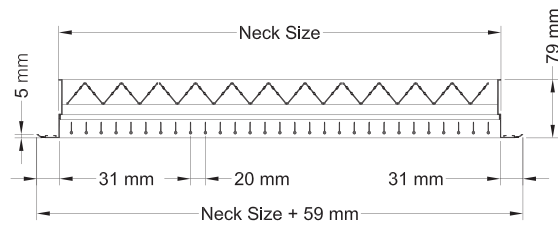
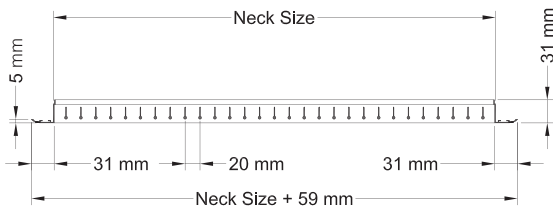

Section : 2-WSG-V

Section : 2-WSG-V(WD)

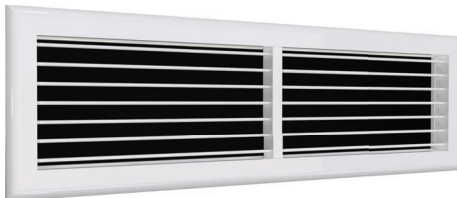
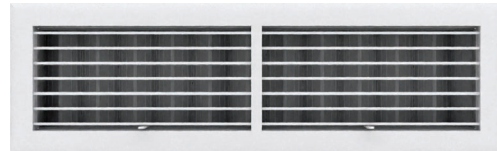
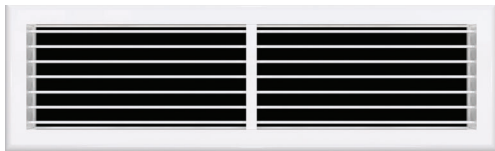

Model : 2-WSG-H

Model : 2-WSG-H(WD)

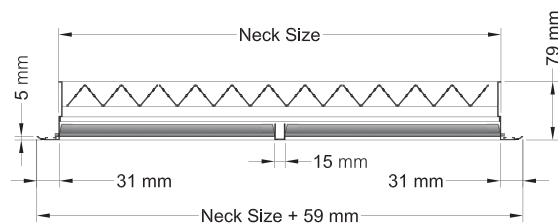
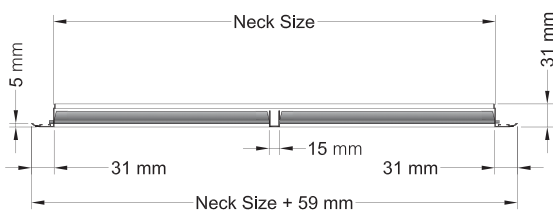

Section : 2-WSG-H

Section : 2-WSG-H(WD)

DOUBLE DEFLECTION SUPPLY AIR GRILLE : MODEL 4-WSG

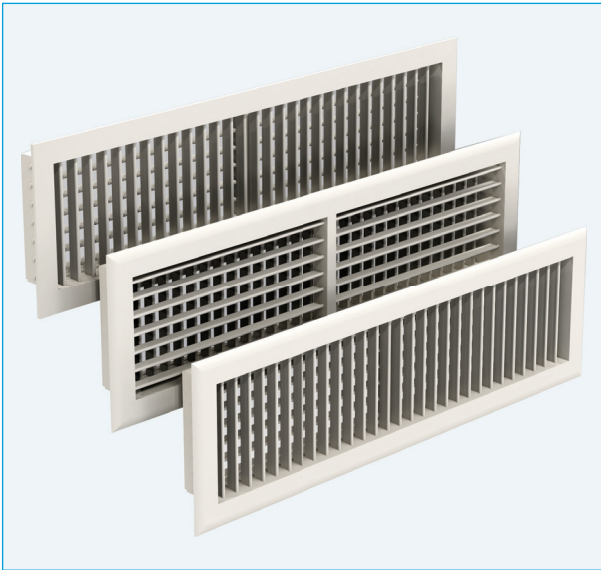

Komfort Flow air grilles and registers are constructed from extruded aluminum comprising with 2 sets of the adjustable blades which can be adjusted to 4 ways air patterns. The front and the rear blades can be arranged either vertical blade or horizontal blade. The aerofoil blade provide maximum and actual directional air flow with minimum noise level.

Nylon boots fixed between blades and frame that can prevent the click sound and also keep the blades remained at the set position. (In powder coated painting model, spring wire will be used instead of the boots.)

Optional opposed blade volume control damper can be fixed with any type of supply grilles and registers.

The available frame sizes are 12.7 mm (1/2"), 20 mm, 25.4 mm (1"), and 31 mm. (1 1/4").

Blade Arrangement

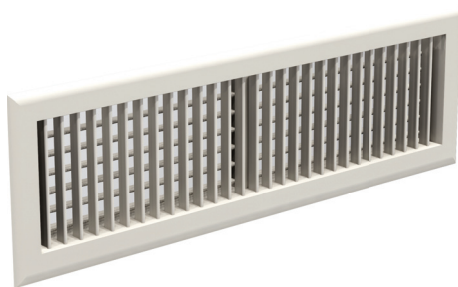

Model : 4-WSG-V
Vertical front blade - Horizontal rear blade



Model : 4-WSG-H
Horizontal front blade - Vertical rear blade

Frame Selection

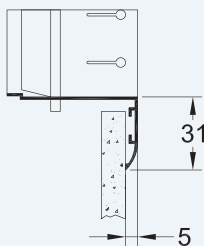

Standard Curve Frame
31 mm. (1 1/4")

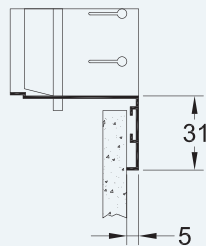

Flat Frame
31 mm. (1 1/4")

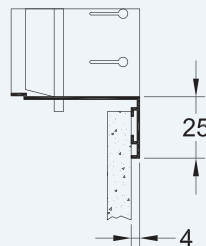

Flat Frame
25 mm (1")

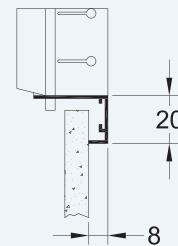

Flat Frame
20 mm

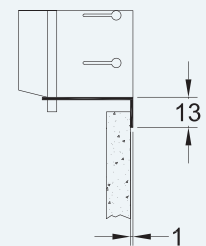

Flat Frame
13 mm (1/2")

Standard Curve Frame 31 mm

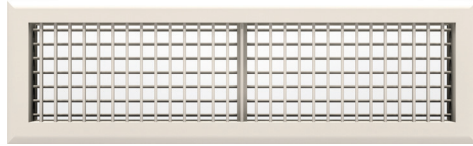

Model : 4-WSG-V

Model : 4-WSG-V(WD)

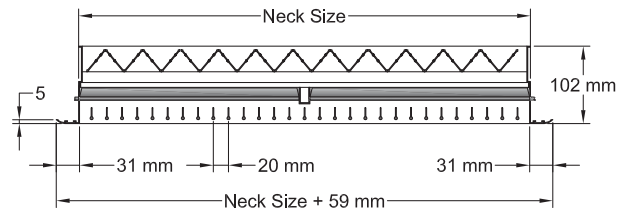
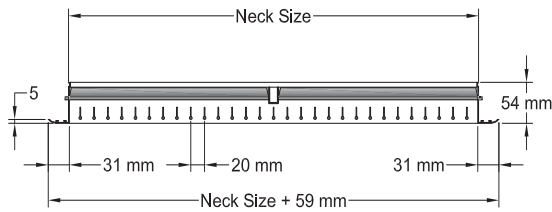

Section : 4-WSG-V

Section : 4-WSG-V(WD)

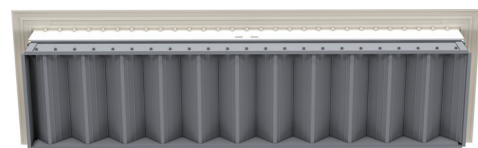
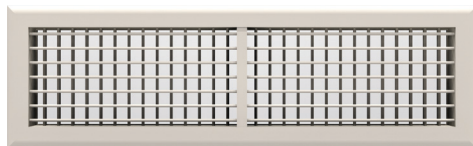

Model : 4-WSG-H

Model : 4-WSG-H(WD)

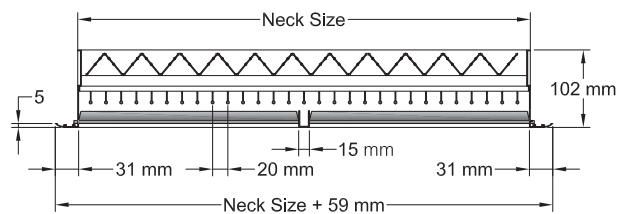
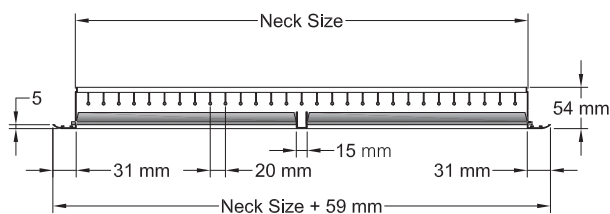

Section : 4-WSG-H

Section : 4-WSG-H(WD)

Flat Frame 31 mm

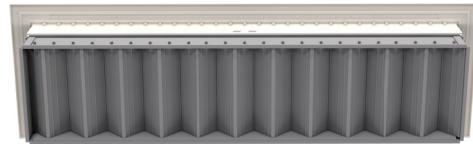
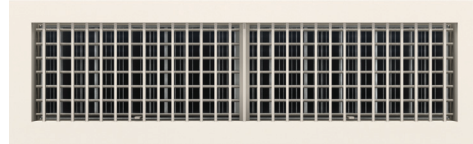

Model : 4-WSG-VF

Model : 4-WSG-VF(WD)

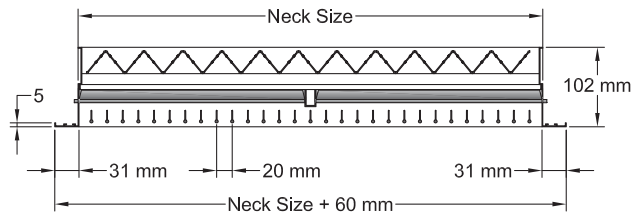
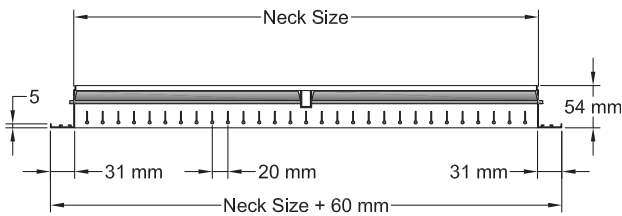

Section : 4-WSG-VF

Section : 4-WSG-VF(WD)

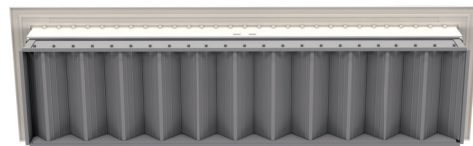
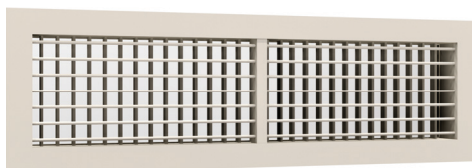
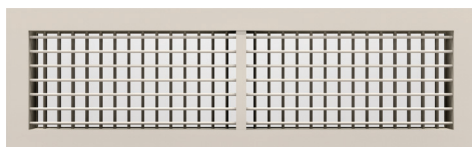

Model : 4-WSG-HF

Model : 4-WSG-HF(WD)

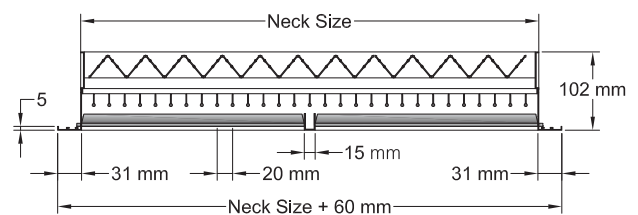
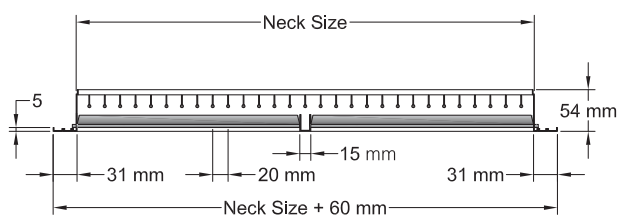

Section : 4-WSG-HF

Section : 4-WSG-HF(WD)

Flat Frame 25 mm (1")

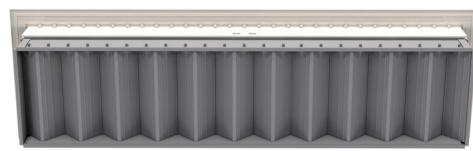
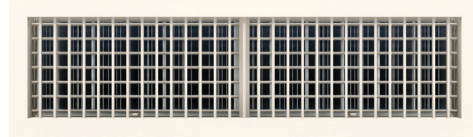
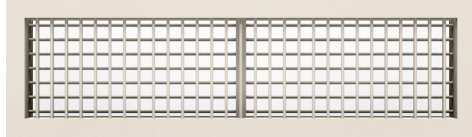

Model : 4-WSG-VF25

Model : 4-WSG-VF25(WD)

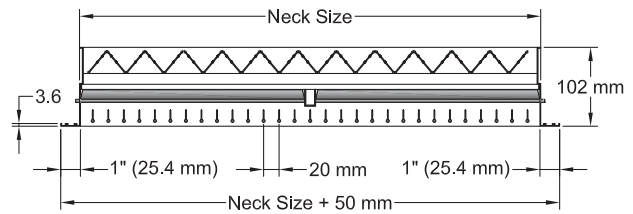
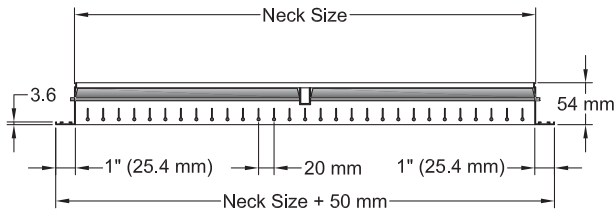

Section : 4-WSG-VF25

Section : 4-WSG-VF25(WD)

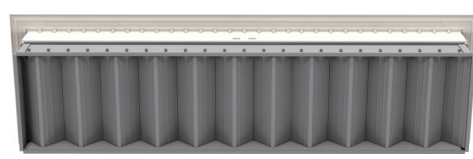
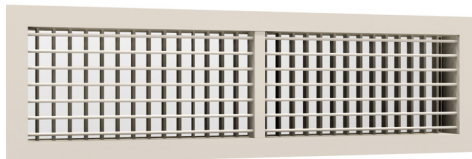
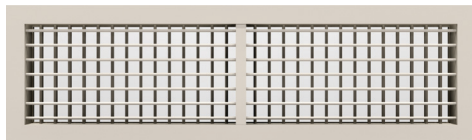

Model : 4-WSG-HF25

Model : 4-WSG-HF25(WD)

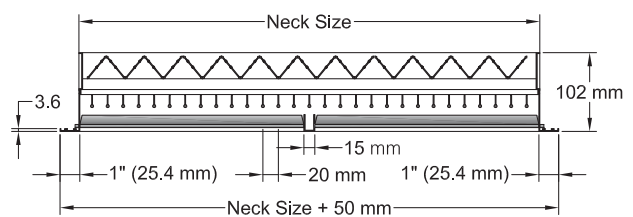
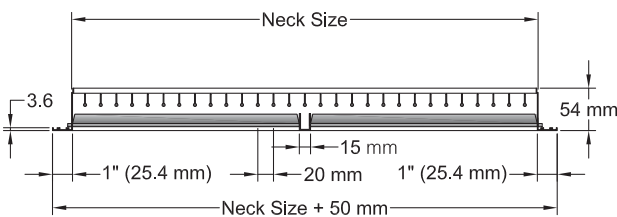

Section : 4-WSG-HF25

Section : 4-WSG-HF25(WD)

Flat Frame 20 mm

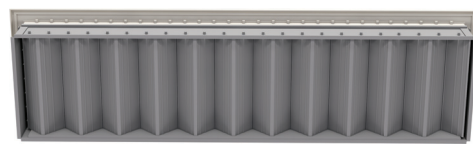
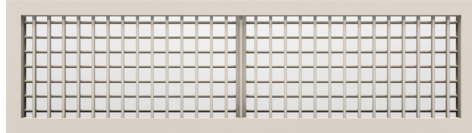

Model : 4-WSG-VF20

Model : 4-WSG-VF20(WD)

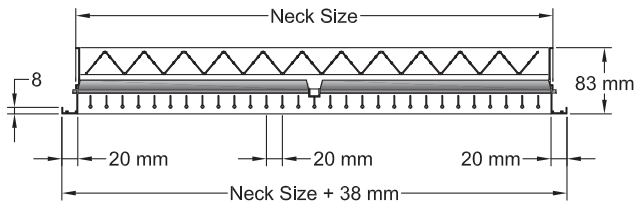
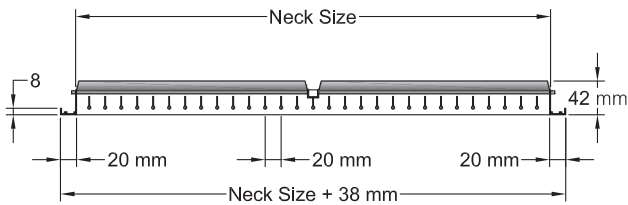

Section : 4-WSG-VF20

Section : 4-WSG-VF20(WD)

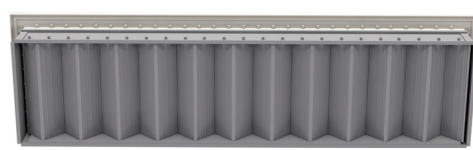
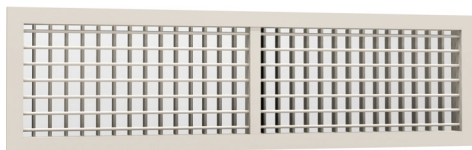
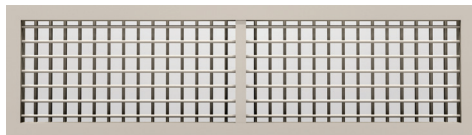

Model : 4-WSG-HF20

Model : 4-WSG-HF20(WD)

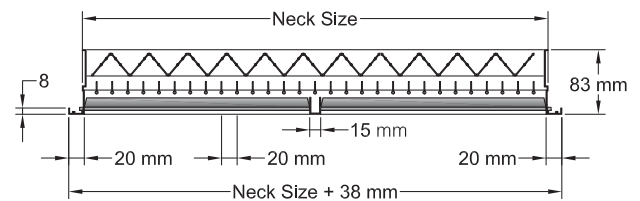
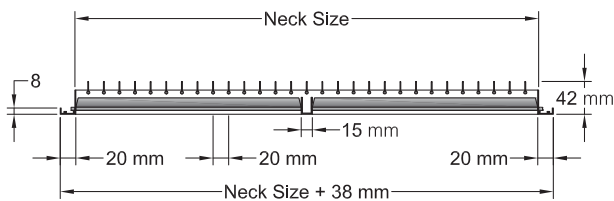

Section : 4-WSG-HF20

Section : 4-WSG-HF20(WD)

Flat Frame 13 mm (1/2")

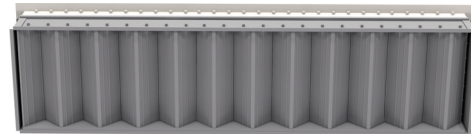
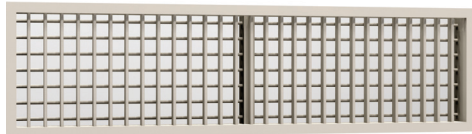
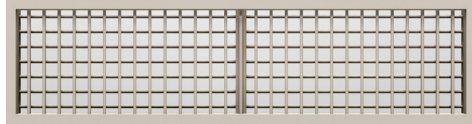

Model : 4-WSG-VF13

Model : 4-WSG-VF13(WD)

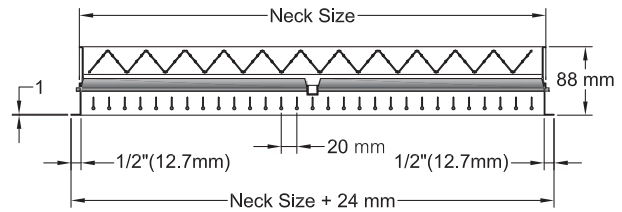
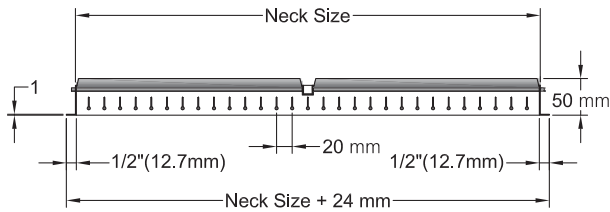

Section : 4-WSG-VF13

Section : 4-WSG-VF13(WD)

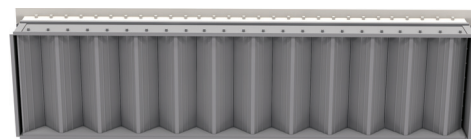
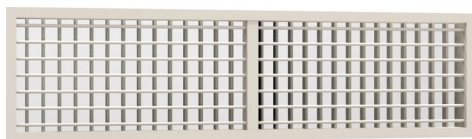
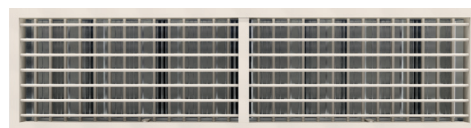
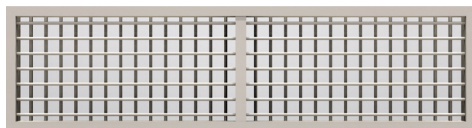

Model : 4-WSG-HF13

Model : 4-WSG-HF13(WD)

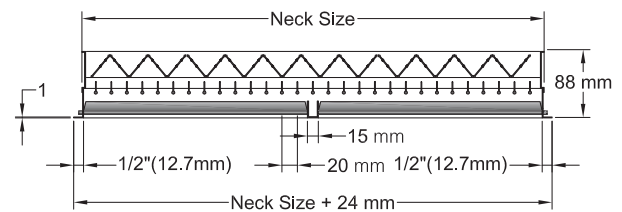
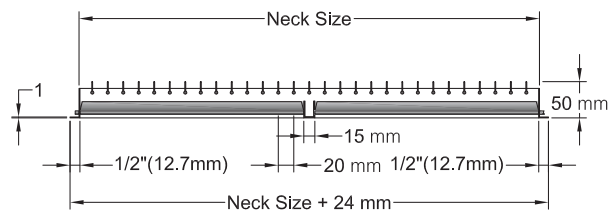

Section : 4-WSG-HF13

Section : 4-WSG-HF13(WD)

Opposed blade volume damper

The opposed blade volume damper is constructed from the extruded aluminum and can be fitted to any type of the grille frame. The damper can be adjusted by the standard lever or the optional screw type without removing the grille.

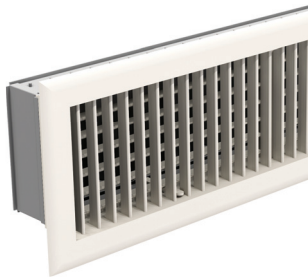

Standard lever for front vertical blade grille



Standard lever for front horizontal blade grille



Optional screw type adjusted damper

Installation

The double deflection grille can be installed by fixing the screw at the front frame, side neck or using support at the back of the grille

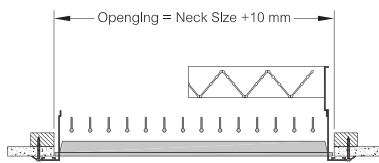

Screw at the front frame

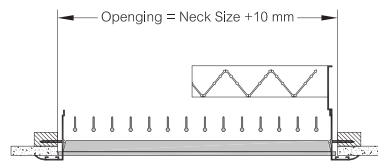

Screw at the side neck

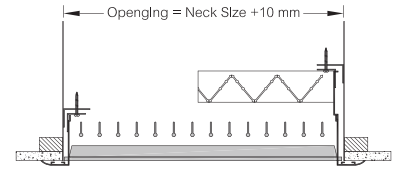

Screw at the back support

Multiple section for double deflection grille



Front vertical blade grille

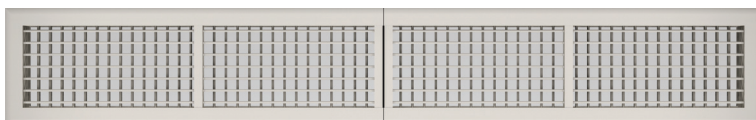
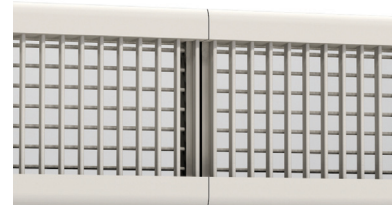

Front horizontal blade grille

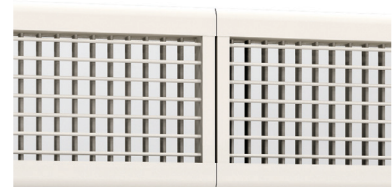

Performance Data

Duct Size in x in	Core Area (Sq.ft.)	Core Velocity (FPM) Vel. Pressure (in.wg.)	300	400	500	600	700	800	1000	1200	1400	1600
			0.0056	0.01	0.0156	0.0224	0.0305	0.0399	0.0623	0.0898	0.1222	0.1596
8 x 6 10 x 5 12 x 4	0.29	Flow Rate (CFM)	86	115	143	172	201	229	286	344	401	458
		Static Pressure (IN.WG.)	0.02	0.04	0.06	0.07	0.10	0.12	0.20	0.30	0.40	0.52
		Sound (NR Level)	<10	<10	<10	<10	13	15	23	30	35	40
		Throw (100 FPM) (FT.)	8	11	14	16	18	19	21	24	26	29
12 x 6 14 x 5 18 x 4	0.44	Flow Rate (CFM)	132	176	220	264	307	351	439	527	615	703
		Static Pressure (IN.WG.)	0.02	0.04	0.05	0.08	0.10	0.14	0.22	0.30	0.40	0.52
		Sound (NR Level)	<10	<10	<10	14	18	22	28	35	38	45
		Throw (100 FPM) (FT.)	10	14	17	20	22	24	28	31	33	36
18 x 6 22 x 5 28 x 4	0.67	Flow Rate (CFM)	201	267	334	401	468	535	668	802	936	1,069
		Static Pressure (IN.WG.)	0.02	0.03	0.06	0.08	0.11	0.14	0.21	0.30	0.40	0.50
		Sound (NR Level)	<10	<10	13	18	23	27	33	39	45	48
		Throw (100 FPM) (FT.)	12	16	21	25	28	30	33	37	41	43
20 x 6 24 x 5 30 x 4	0.74	Flow Rate (CFM)	223	298	372	447	521	596	745	894	1,043	1,192
		Static Pressure (IN.WG.)	0.02	0.04	0.05	0.08	0.11	0.14	0.21	0.29	0.40	0.43
		Sound (NR Level)	<10	<10	13	18	24	28	34	40	45	47
		Throw (100 FPM) (FT.)	12	18	21	26	30	32	36	39	43	43
20 x 8 27 x 6 40 x 4	1.02	Flow Rate (CFM)	305	406	508	609	711	813	1,016	1,219	1,422	1,625
		Static Pressure (IN.WG.)	0.02	0.03	0.06	0.08	0.10	0.14	0.22	0.30	0.40	0.52
		Sound (NR Level)	<10	10	18	22	27	30	38	44	50	55
		Throw (100 FPM) (FT.)	16	20	26	32	34	37	42	46	49	53
24 x 8 32 x 6 48 x 4	1.22	Flow Rate (CFM)	367	490	612	734	857	979	1,224	1,469	1,714	1,958
		Static Pressure (IN.WG.)	0.02	0.04	0.06	0.07	0.10	0.14	0.22	0.30	0.40	0.50
		Sound (NR Level)	<10	13	18	23	28	33	40	46	50	55
		Throw (100 FPM) (FT.)	16	22	30	33	38	41	46	50	53	56
32 x 10 40 x 8 54 x 6 80 x 4	2.08	Flow Rate (CFM)	623	831	1,039	1,247	1,455	1,663	2,078	2,494	2,909	3,325
		Static Pressure (IN.WG.)	0.02	0.04	0.06	0.08	0.11	0.14	0.18	0.30	0.40	0.52
		Sound (NR Level)	12	18	24	30	34	38	43	45	58	65
		Throw (100 FPM) (FT.)	22	30	37	46	49	52	56	59	62	69
36 x 12 44 x 10 54 x 8 72 x 6	2.84	Flow Rate (CFM)	851	1,134	1,418	1,701	1,985	2,268	2,835	3,402	3,969	4,536
		Static Pressure (IN.WG.)	0.02	0.04	0.06	0.08	0.11	0.13	0.22	0.30	0.40	0.05
		Sound (NR Level)	13	22	28	33	38	40	48	55	61	64
		Throw (100 FPM) (FT.)	25	34	43	52	56	59	65	69	72	75
42 x 14 49 x 12 58 x 10 74 x 8	3.89	Flow Rate (CFM)	1,167	1,556	1,945	2,334	2,723	3,113	3,891	4,669	5,447	6,225
		Static Pressure (IN.WG.)	0.02	0.04	0.06	0.08	0.11	0.14	0.20	0.32	0.44	0.52
		Sound (NR Level)	17	24	30	35	40	45	53	58	63	67
		Throw (100 FPM) (FT.)	30	41	51	59	64	67	72	78	86	91
48 x 18 54 x 16 62 x 14 72 x 12	5.77	Flow Rate (CFM)	1,732	2,309	2,886	3,464	4,041	4,618	5,773	6,927	8,082	9,236
		Static Pressure (IN.WG.)	0.02	0.03	0.06	0.08	0.11	0.00	0.00	0.00	0.00	0.00
		Sound (NR Level)	20	26	33	40	45	51	57	64	68	70
		Throw (100 FPM) (FT.)	36	46	59	66	74	81	87	97	107	116

Remark

- Core area calculated from the actual neck size which is reduced from duct size by 1/2 inch.
- Corrections of grille with damper
 - Throw x 1.03
 - Static Pressure x 1.12
 - NC +4

Unit Conversion

Flow Rate: 1 CMH = 0.588 CFM
 1 L/S = 2.12 CFM
 Velocity : 1 m/s = 196.85 FPM
 Area : 1 Sq.M. = 10.76 Sq.Ft.
 Length : 1 M = 3.3 Ft.
 Pressure : 1 Pa = 0.004 in.wg.

DOUBLE DEFLECTION SUPPLY AIR LOUVER : MODEL 4-SAL



Komfort Flow Supply Air Louver are constructed from extruded aluminum comprising with 2 sets of the adjustable blades which can be adjusted to 4 ways air patterns. The front and the rear blades can be arranged either vertical blade or horizontal blade. The aerofoil blade provide maximum and actual directional air flow with minimum noise level.

Rubber boots fixed between blades and frame that can prevent the click sound and also keep the blades remained at the set position.

Optional opposed blade volume control damper can be installed at the back of SAL.

Front Border	: 30 mm.
Frame Deep	: 123 mm.
Blade Size	: 60 mm.
Blade Spacing	: 50 mm.

Blade Arrangement

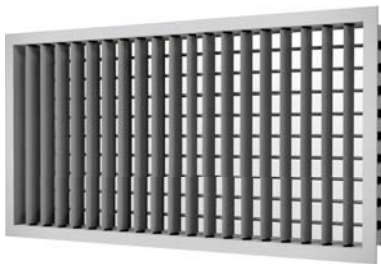

Model : 4-SAL-V
Vertical front blade - Horizontal rear blade

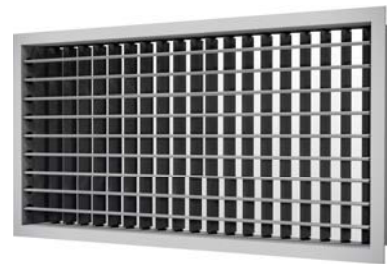

Model : 4-SAL-H
Horizontal front blade - Vertical rear blade

Blade Adjustment

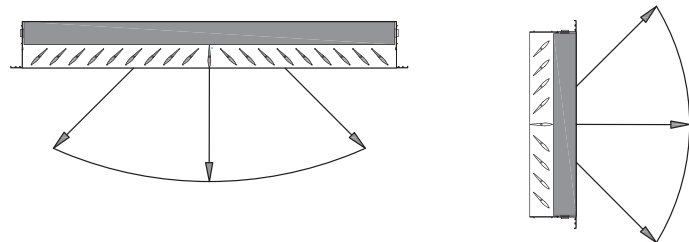
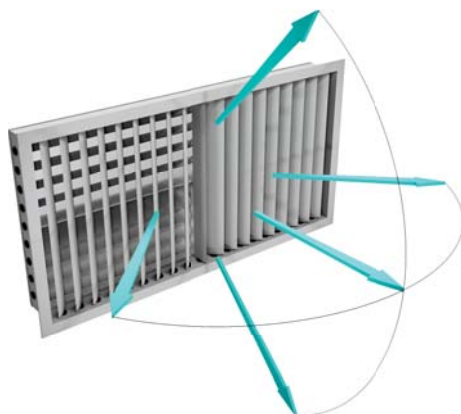

Front and rear blade can be adjusted individually.
Horizontal blade adjusted for up and down flow pattern.
Vertical blade adjusted for left and right flow pattern
Both set of blade can be adjusted approximately 45 degree.

SECTION DETAIL

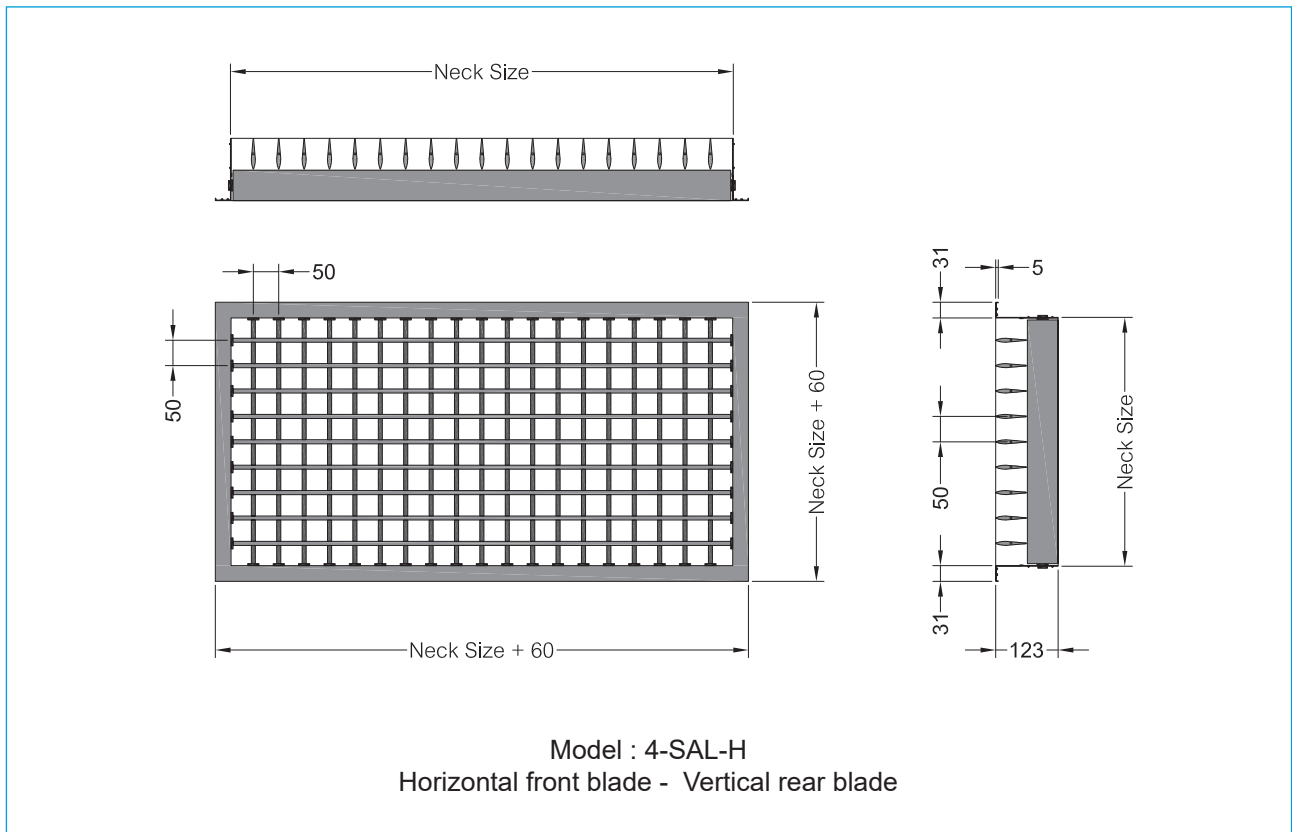
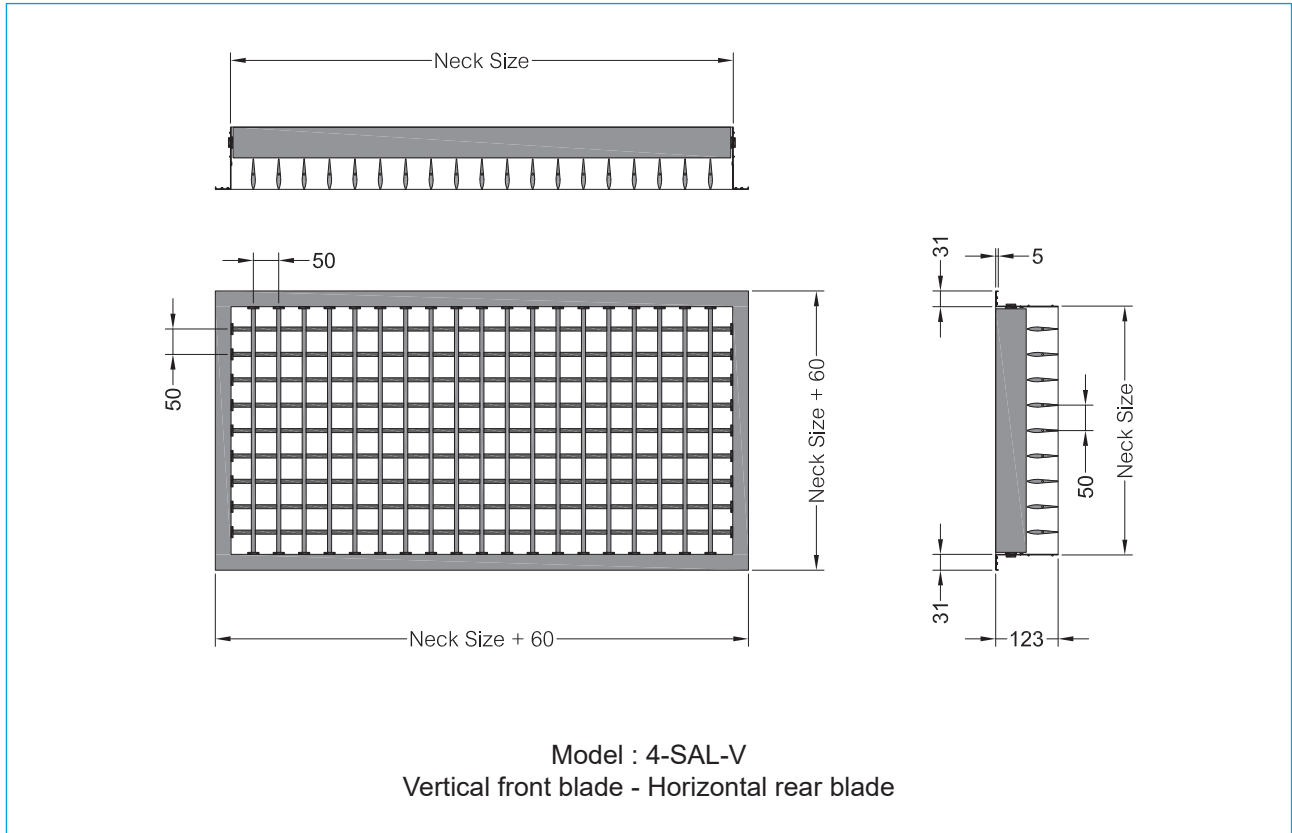

1" Z BLADE - LOUVER AIR GRILLE



Komfort Flow 1" Z blade louver air grille, model 1-HRG, is constructed of the high quality extruded aluminum alloy. The louver blades are fixed at 45 degree deflection. Blade spacing is approximately 20 mm. All grilles can be installed with opposed blade volume damper, filter and insect screen.

Grille with damper (Register)

The grille is installed the opposed blade volume damper at the back which can be adjusted the air flow rate by not removing the grille.

Return air grille - removable core type

The grille has the double frame and the core can be easily removed by pulling the spring pin.

Choices of fully removable core or removable core hinge type. Optional filter can be fitted at back of the grille.

Features and Options



Fixed 45 degree - 1" Z Louver blade

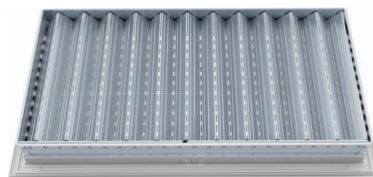

Grille with opposed blade volume damper (Register)



Double frame for fully removable core type

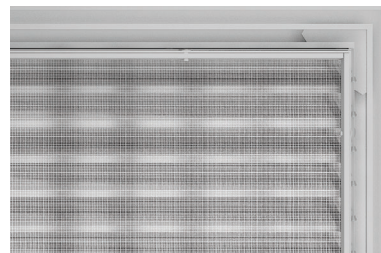

Option with insect screen





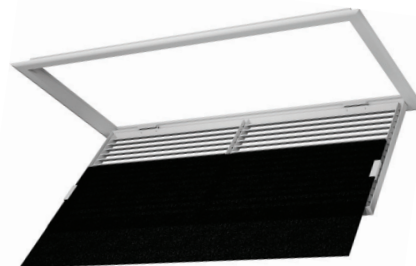





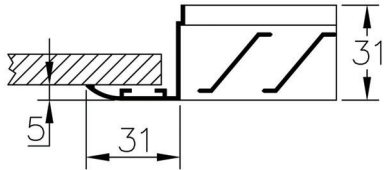

Double frame for removable core hinge type

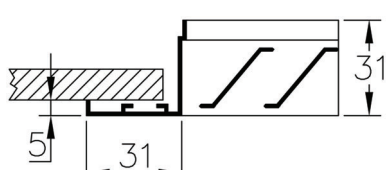

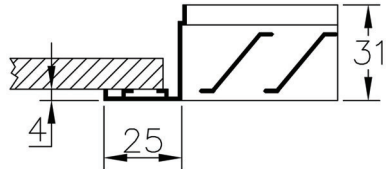
Option with filter

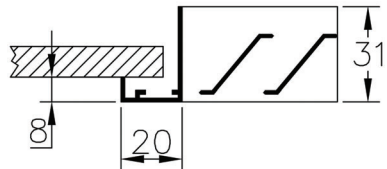
Frame Selection

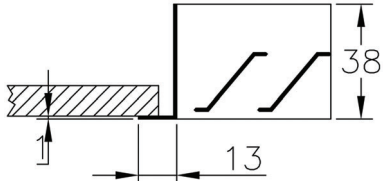
The standard 31 mm curve frame and the other frame types are available to allow the grille to be fully integrated with the interior design.

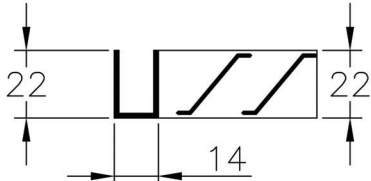
<p>Standard 31 mm Curve Frame</p>  	<p>31 mm Flat Frame</p>  
<p>25 mm Flat Frame</p>  	<p>20 mm Flat Frame</p>  
<p>13 mm Flat Frame</p>  	<p>14 mm U Frame</p>  

Section Details - Standard 31 mm Curve Frame



Model : 1-HRG

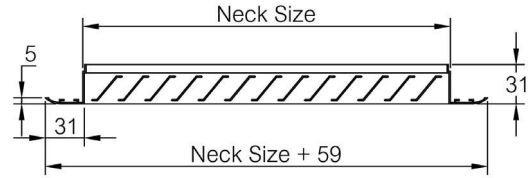

Section : 1-HRG

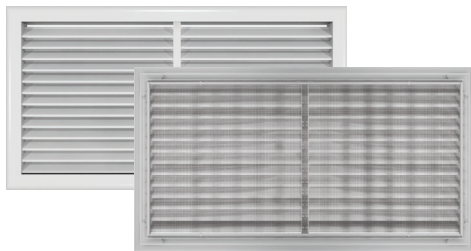

Model : 1-HRG(INS)

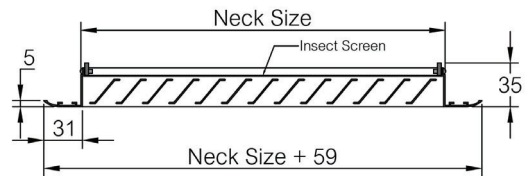

Section : 1-HRG(INS)



Model : 1-HRG(WD)

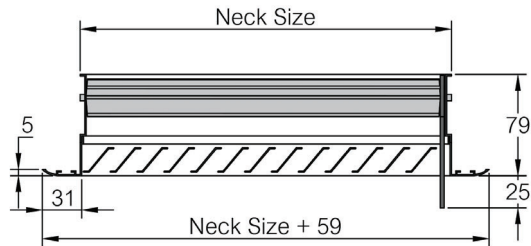

Section : 1-HRG(WD)



Model : 1-HRG-R

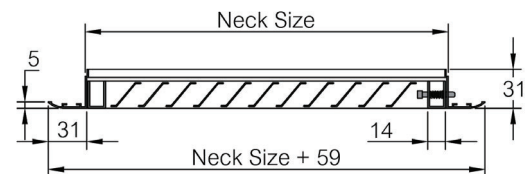

Section : 1-HRG-R

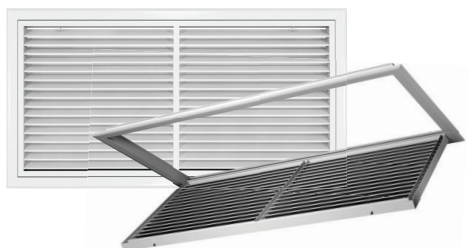

Model : 1-HRG-R (Hinge Type)

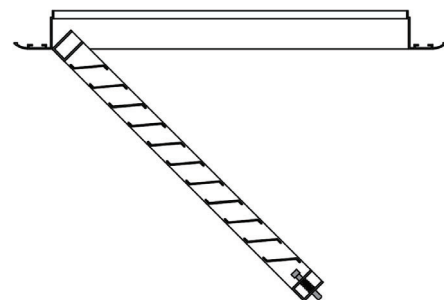

Section : 1-HRG-R (Hinge Type)

Section Detail - Standard 31 mm Curve Frame

Removable core grille with black synthetic filter or black nylon filter



Model : 1-HRG-R + Black Syn. Filter
1-HRG-R + Nylon Filter

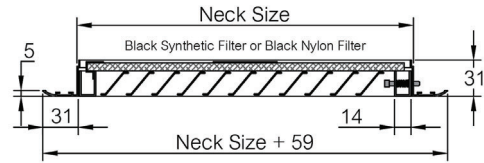

Fully Removable Type

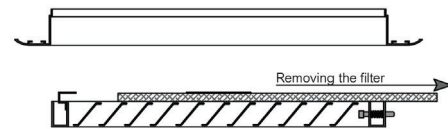

Removable Hinge Type

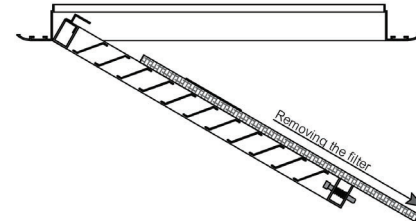

Section : 1-HRG-R + Black Syn. Filter
1-HRG-R + Nylon Filter

Removable core grille with white synthetic filter or aluminum filter



Model : 1-HRG-R + White Syn. Filter
1-HRG-R + Aluminum Filter

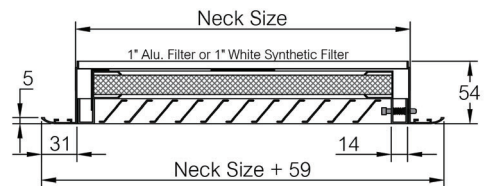

Fully Removable Type

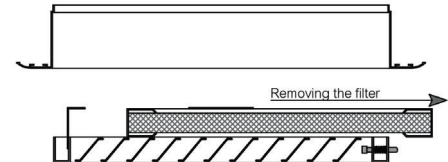

Removable Hinge Type

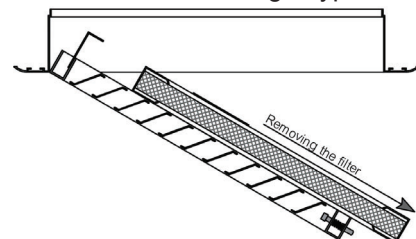

Section : 1-HRG-R + White Syn. Filter
1-HRG-R + Aluminum Filter

Section Details - 30 mm Flat Frame



Model : 1-HRG-F

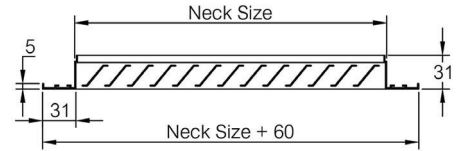

Section : 1-HRG-F

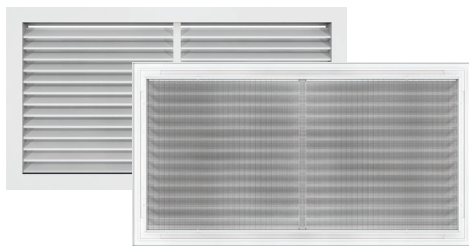

Model : 1-HRG-F (INS)

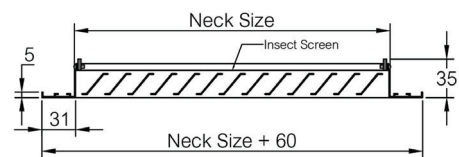

Section : 1-HRG-F (INS)

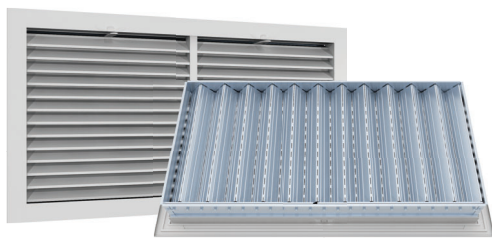

Model : 1-HRG-F (WD)

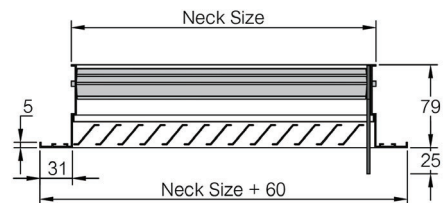

Section : 1-HRG-F (WD)

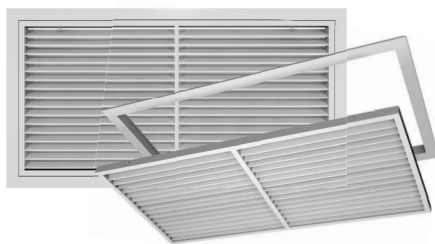

Model : 1-HRG-RF

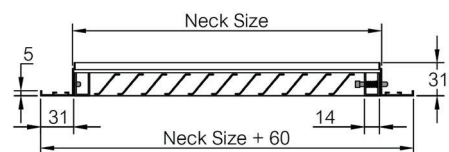

Section : 1-HRG-RF

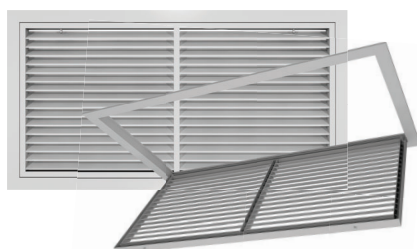

Model : 1-HRG-RF (Hinge Type)

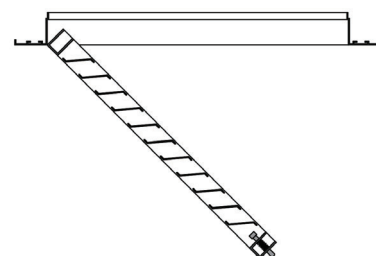

Section : 1-HRG-RF (Hinge Type)

Performance Data

SIZE	Core Area (Sq.ft.)	Duct Size		Neck Velocity	FPM	200	300	400	500	600	700	800	900	1000	1200	1400	1600	
		in	x in															
A	0.29	12 x 4 8 x 6		Flow Rate	CFM	57	86	115	143	172	201	229	258	286	344	401	458	
					L/S	27	41	54	68	81	95	108	122	135	162	189	216	
					Static Pressure	in.wg.	0.00	0.01	0.02	0.03	0.05	0.07	0.10	0.13	0.16	0.26	0.32	0.52
						Pa	1	2	4	8	12	18	24	32	40	65	80	130
						NC	<10	<10	14	18	22	26	28	32	34	37	40	45
B	0.67	27 x 4 18 x 6 14 x 8		Flow Rate	CFM	134	201	267	334	401	468	535	602	668	802	936	1,069	
					L/S	63	95	126	158	189	221	252	284	315	378	441	504	
					Static Pressure	in.wg.	0.01	0.02	0.04	0.07	0.12	0.16	0.24	0.30	0.40	0.64	0.88	1.20
						Pa	2	6	11	18	30	40	60	75	100	160	220	300
						NC	<10	18	24	28	33	36	39	42	45	49	51	55
C	1.02	26 x 6 20 x 8 12 x 12		Flow Rate	CFM	203	305	406	508	609	711	813	914	1,016	1,219	1,422	1,625	
					L/S	96	144	192	240	287	335	383	431	479	575	671	767	
					Static Pressure	in.wg.	0.01	0.02	0.04	0.08	0.11	0.15	0.20	0.30	0.40	0.56	0.80	1.08
						Pa	2	6	11	19	28	38	50	75	100	140	200	270
						NC	12	20	26	31	34	38	40	44	47	50	53	58
D	1.42	28 x 8 22 x 10 18 x 12		Flow Rate	CFM	284	426	567	709	851	993	1,135	1,277	1,418	1,702	1,986	2,269	
					L/S	134	201	268	335	401	468	535	602	669	803	937	1,070	
					Static Pressure	in.wg.	0.01	0.02	0.05	0.08	0.12	0.18	0.27	0.32	0.40	0.64	0.88	1.20
						Pa	2	6	13	20	30	45	68	80	100	160	220	300
						NC	14	22	28	33	37	40	44	45	47	50	53	56
E	1.55	30 x 8 24 x 10 20 x 12		Flow Rate	CFM	310	465	620	775	930	1,085	1,240	1,395	1,550	1,860	2,170	2,481	
					L/S	146	219	293	366	439	512	585	658	731	878	1,024	1,170	
					Static Pressure	in.wg.	0.01	0.02	0.05	0.08	0.12	0.22	0.24	0.34	0.44	0.64	1.00	1.20
						Pa	2	6	12	19	30	55	60	85	110	160	250	300
						NC	14	22	28	33	37	42	43	46	48	51	55	57
F	1.95	38 x 8 30 x 10 26 x 12		Flow Rate	CFM	389	584	778	973	1,168	1,362	1,557	1,752	1,946	2,335	2,725	3,114	
					L/S	184	275	367	459	551	643	734	826	918	1,102	1,285	1,469	
					Static Pressure	in.wg.	0.01	0.02	0.04	0.07	0.10	0.16	0.22	0.28	0.36	0.48	0.80	1.12
						Pa	2	5	10	18	26	40	55	70	90	120	200	280
						NC	14	23	28	34	38	41	44	46	48	50	55	58
G	2.34	45 x 8 36 x 10 30 x 12		Flow Rate	CFM	468	703	937	1,171	1,405	1,639	1,874	2,108	2,342	2,810	3,279	3,747	
					L/S	221	331	442	552	663	773	884	994	1,105	1,326	1,547	1,768	
					Static Pressure	in.wg.	0.01	0.02	0.05	0.08	0.12	0.17	0.24	0.32	0.48	0.64	0.96	1.24
						Pa	2	6	12	20	30	43	60	80	120	160	240	310
						NC	17	24	31	35	39	43	45	48	50	52	54	56
H	3.82	42 x 14 36 x 16 32 x 18		Flow Rate	CFM	764	1,146	1,528	1,911	2,293	2,675	3,057	3,439	3,821	4,585	5,350	6,114	
					L/S	360	541	721	901	1,081	1,262	1,442	1,622	1,802	2,163	2,523	2,884	
					Static Pressure	in.wg.	0.01	0.03	0.05	0.08	0.11	0.16	0.26	0.32	0.48	0.68	1.04	1.28
						Pa	2	7	13	20	28	40	65	80	120	170	260	320
						NC	18	28	34	38	41	45	48	50	51	53	55	58
I	5.89	55 x 16 44 x 20 36 x 24		Flow Rate	CFM	1,178	1,767	2,356	2,945	3,534	4,123	4,713	5,302	5,891	7,069	8,247	9,425	
					L/S	556	834	1,111	1,389	1,667	1,945	2,223	2,501	2,779	3,334	3,890	4,446	
					Static Pressure	in.wg.	0.01	0.02	0.05	0.08	0.11	0.18	0.27	0.36	0.48	0.72	1.00	1.40
						Pa	2	6	12	20	28	45	68	90	120	180	250	350
						NC	17	28	35	40	43	46	48	50	53	55	57	60
J	7.75	58 x 20 48 x 24 42 x 28		Flow Rate	CFM	1,550	2,326	3,101	3,876	4,651	5,426	6,201	6,977	7,752	9,302	10,852	12,403	
					L/S	731	1,097	1,463	1,828	2,194	2,560	2,925	3,291	3,656	4,388	5,119	5,850	
					Static Pressure	in.wg.	0.01	0.03	0.05	0.09	0.13	0.20	0.28	0.36	0.44	0.72	1.12	1.40
						Pa	3	7	13	22	32	50	70	90	110	180	280	350
						NC	23	31	37	42	45	47	50	53	54	56	59	61

Performance Data

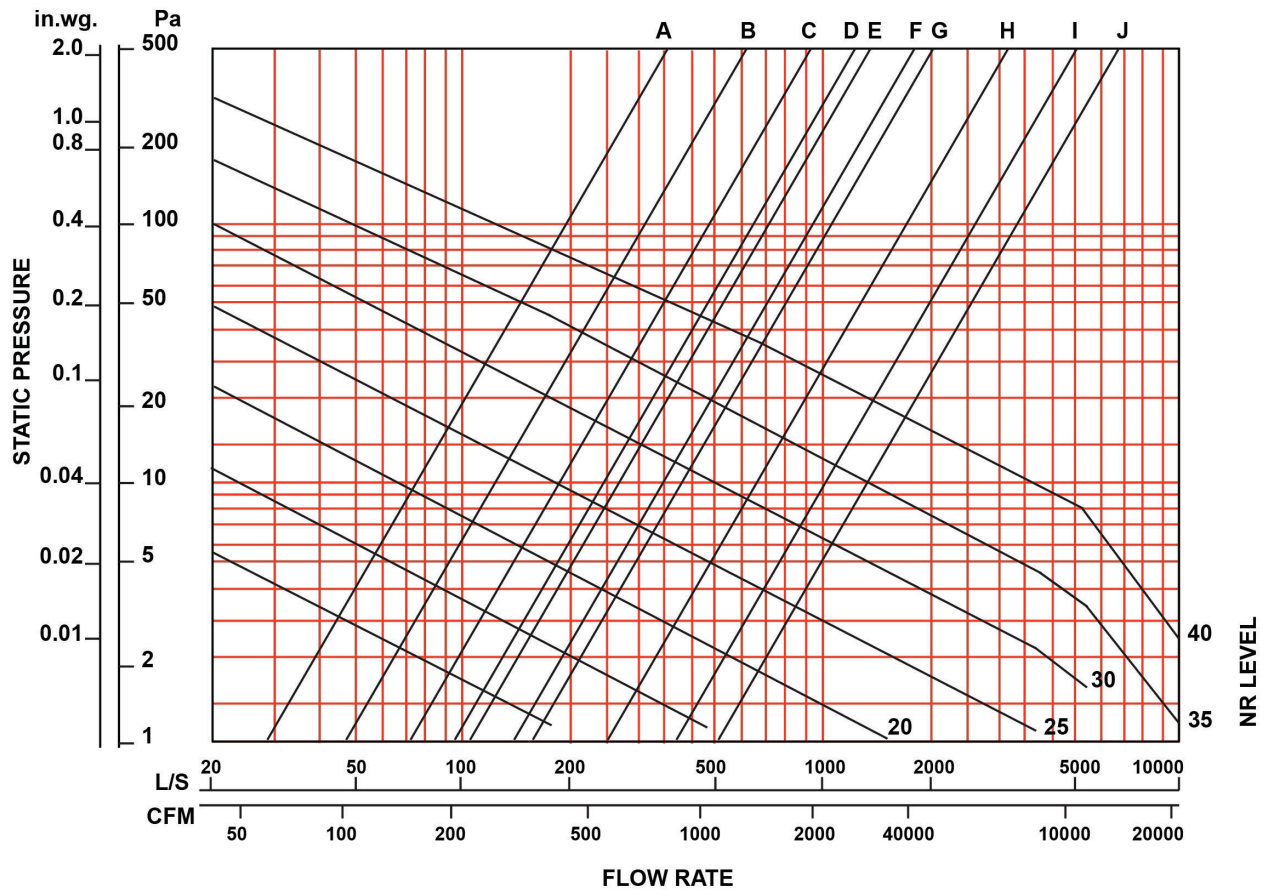

Reference grille size for performance graph

GRILLE	SIZE	NECK AREA mm x mm
A	8" x 6"	190 x 140
B	18" x 6"	292 x 140
C	20" x 8"	444 x 140
D	22" x 10"	495 x 140
E	24" x 10"	495 x 190
F	30" x 10"	597 x 190
G	36" x 10"	800 x 241
H	36" x 16"	899 x 288
I	44" x 20"	1054 x 343
J	48" x 24"	1206 x 444

Perforated Grille **Model : PFR**

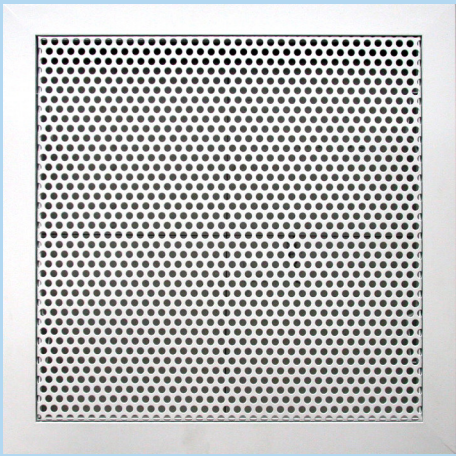

Fig.1 shows Model PFR

Product Features

Komfort Flow PFR Perforated Grilles are available for air distribution, return air, and architectural application. These can be made in a choices of steel or aluminum to suit your desire application.

PFR Model is composed of the removable core. By using sheet metal spring pin, it's easy to remove for cleaning or maintenance.

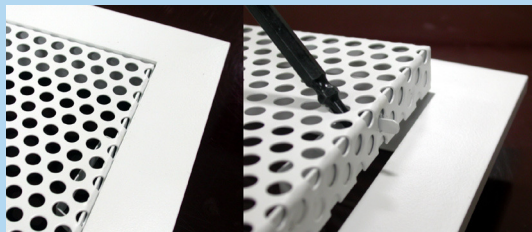

Fig.2 show how to remove the core

Material

The frames are constructed from extruded aluminum with choice of steel or aluminum core.

Optional gauge material available on Request.

Finishing

Komfort Flow Perforated Grilles are finished with the powder coating in white color. The custom color is upon request.

Grilles

Perforated screen with 1/4" diameter holes on 3/8" center to center

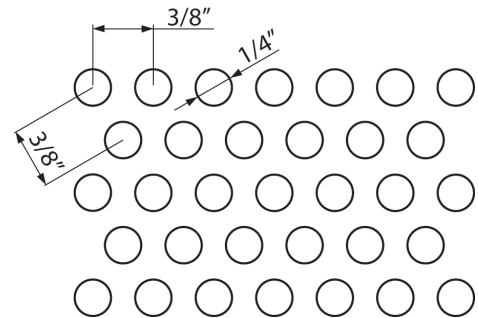

Section Details

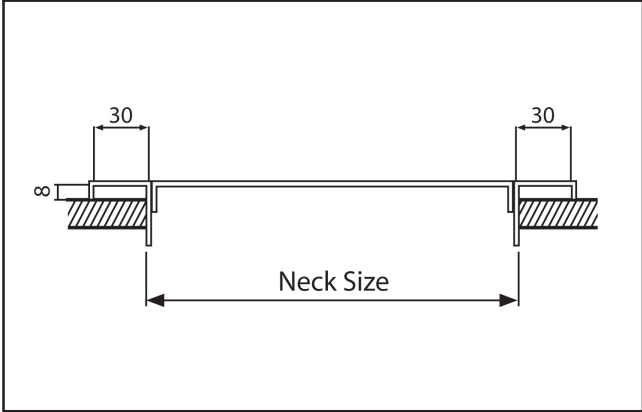

Installation Details

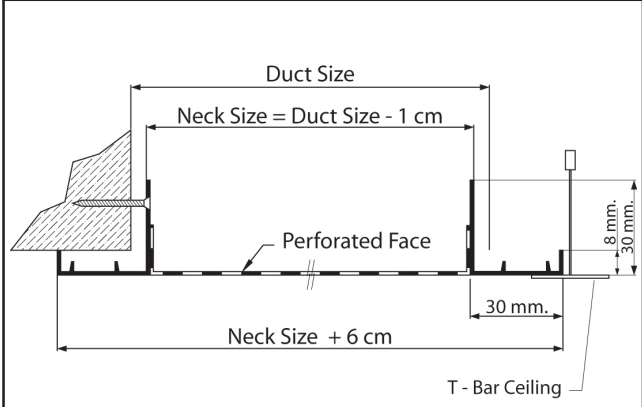

Core Area Sq. Ft.	Nominal Size (inch)	Core Velocity	NC 20							30				
			Velocity	Pressure						600	700	800	900	1000
				0.002	0.006	0.010	0.016	0.022	0.031					
Negative SP			0.019	0.043	0.076	0.118	0.171	0.232	0.303	0.384	0.474			
0.15	6 x 5	CFM	30	45	60	75	90	105	120	135	150			
	7 x 4	NC	--	--	--	20	25	29	33	36	39			
0.18	6 x 6	CFM	36	54	72	90	108	126	144	162	180			
	7 x 5	NC	--	--	--	20	25	29	33	36	39			
0.22	7 x 6	CFM	44	66	88	110	132	154	176	198	220			
	7 x 5	NC	--	--	--	20	25	29	33	36	39			
0.26	6 x 6	CFM	52	78	104	130	156	182	208	234	260			
	10 x 5	NC	--	--	--	20	25	29	33	36	39			
0.30	14 x 4	CFM	60	90	120	150	180	210	240	270	300			
		NC	--	--	--	20	25	29	33	36	39			
0.34	10 x 6	CFM	68	102	136	170	204	238	272	306	340			
	12 x 5	NC	--	--	--	20	25	29	33	36	39			
0.39	8 x 8	CFM	78	117	156	195	234	273	312	351	390			
	14 x 5	NC	--	--	--	20	25	29	33	36	39			
0.46	20 x 4	CFM	92	138	184	230	276	322	368	414	460			
	16 x 5	NC	--	--	--	20	25	29	33	36	39			
0.52	24 x 4	CFM	104	156	208	260	312	364	416	468	520			
	18 x 5	NC	--	--	--	20	25	29	33	36	39			
0.60	28 x 4	CFM	120	180	240	300	360	420	480	540	600			
	20 x 5	NC	--	--	--	20	25	29	33	36	39			
0.69	30 x 4	CFM	138	207	276	345	414	483	552	621	690			
	24 x 5	NC	--	--	--	20	25	29	33	36	39			
0.81	36 x 4	CFM	162	243	324	405	486	567	648	729	810			
	28 x 5	NC	--	--	--	20	25	29	33	36	39			
0.90	40 x 4	CFM	180	270	360	450	540	630	720	810	900			
	30 x 5	NC	--	--	--	20	25	29	33	36	39			
1.07	48 x 4	CFM	214	321	428	535	642	749	856	963	1070			
	36 x 5	NC	--	--	--	20	25	29	33	36	39			
1.18	34 x 6	CFM	236	354	472	590	708	826	944	1062	1180			
	24 x 8	NC	--	--	--	20	25	29	33	36	39			
1.34	60 x 4	CFM	268	402	536	670	804	938	1072	1206	1340			
	48 x 5	NC	--	--	--	20	25	29	33	36	39			
1.60	72 x 4	CFM	320	480	640	800	960	1120	1280	1440	1600			
	30 x 8	NC	--	--	--	20	25	29	33	36	39			
1.80	60 x 5	CFM	360	540	720	900	1080	1260	1440	1620	1800			
	48 x 6	NC	--	--	--	20	25	29	33	36	39			
2.08	72 x 5	CFM	416	624	832	1040	1248	1456	1664	1872	2080			
	60 x 6	NC	--	--	--	20	25	29	33	36	39			
2.45	72 x 6	CFM	490	735	980	1225	1470	1715	1960	2205	2450			
	48 x 8	NC	--	--	--	20	25	29	33	36	39			
2.78	36 x 12	CFM	556	834	1112	1390	1668	1946	2224	2502	2780			
	30 x 14	NC	--	--	--	20	25	29	33	36	39			
3.11	60 x 8	CFM	622	933	1244	1555	1866	2177	2488	2799	3110			
	48 x 10	NC	--	--	--	20	25	29	33	36	39			
3.61	72 x 8	CFM	722	1083	1444	1805	2166	2527	2888	3249	3610			
	60 x 10	NC	--	--	--	20	25	29	33	36	39			
4.29	48 x 14	CFM	858	1287	1716	2145	2574	3003	3432	3861	4290			
	36 x 18	NC	--	--	--	20	25	29	33	36	39			
4.65	72 x 10	CFM	930	1395	1860	2325	2790	3255	3720	4185	4650			
	48 x 16	NC	--	--	--	20	25	29	33	36	39			
5.58	72 x 12	CFM	1116	1674	2232	2790	3348	3906	4468	5022	5580			
	60 x 14	NC	--	--	--	20	25	29	33	36	39			
6.25	72 x 14	CFM	1250	1875	2500	3125	3750	4375	5000	5625	6250			
	60 x 16	NC	--	--	--	20	25	29	33	36	39			

NC 20 30

Notes:

- All pressures are in inches of water.
- The NC values are based on a room absorption of 10 dB, re 10-12 watts
- Blank (--) indicate an NC level below 15.
- Air flow is in cubic feet per minute, cfm.
- Neg. SP is negative static pressure.

Lattice Grille **Model : LTG**

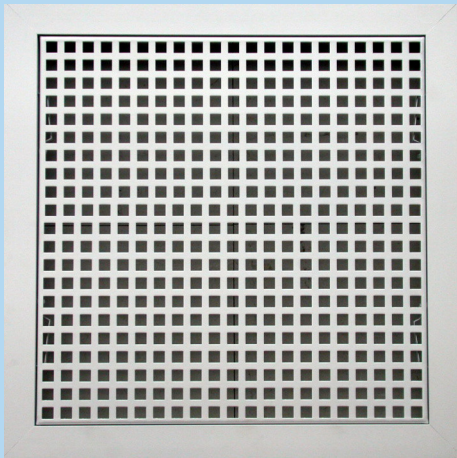

Fig.1 shows Model LTG

Product Features

Komfort Flow LTG Lattice Grilles are available for air distribution, return air, and architectural application. These can be made in a choice of steel or aluminum to suit any application.

Komfort Flow Lattice Grilles are composed of the removable core. By using sheet metal spring pin, it's easy to remove for cleaning or maintenance.



Fig.2 show how to remove the core

Material

The frames are constructed from extruded aluminum and a choice of steel or aluminum core.

Optional gauge material available on Request.

Finishing

Komfort Flow Perforated Grilles are finished with the powder coating in white color. The custom color is upon request.

LTG10

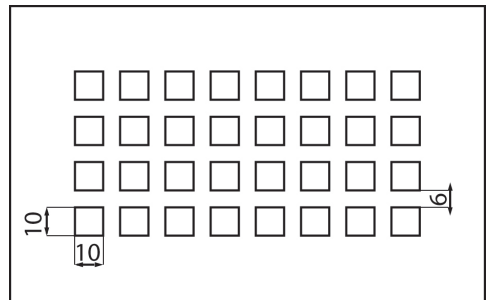

LTG15

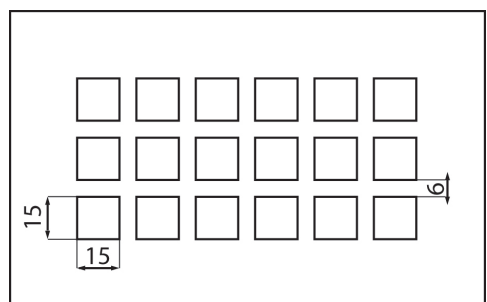

LTG20

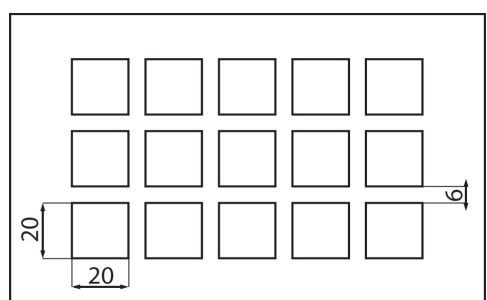

Grilles

10 mm. Square Mesh	LTG 10
15 mm. Square Mesh	LTG 15
20 mm. Square Mesh	LTG 20

Installation Details

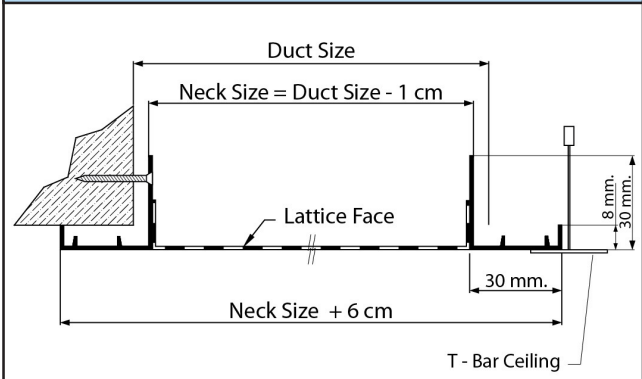

Performance Data

Number of Holes	LTG10 mm.	Number of Holes	LTG10 mm.	Number of Holes	LTG10 mm.	Number of Holes	LTG10 mm.
1	10	21	330	41	650	61	970
2	26	22	346	42	666	62	986
3	42	23	362	43	682	63	1002
4	58	24	378	44	698	64	1018
5	74	25	394	45	714	65	1034
6	90	26	410	46	730	66	1050
7	106	27	426	47	746	67	1066
8	122	28	442	48	762	68	1082
9	138	29	458	49	778	69	1098
10	154	30	474	50	794	70	1114
11	170	31	490	51	810	71	1130
12	186	32	506	52	826	72	1146
13	202	33	522	53	842	73	1162
14	218	34	538	54	858		
15	234	35	554	55	874		
16	250	36	570	56	890		
17	266	37	586	57	906		
18	282	38	602	58	922		
19	298	39	618	59	938		
20	314	40	634	60	954		

Number of Holes	LTG15 mm.	Number of Holes	LTG15 mm.	Number of Holes	LTG15 mm.
1	15	21	435	41	855
2	36	22	456	42	876
3	57	23	477	43	897
4	78	24	498	44	918
5	99	25	519	45	939
6	120	26	540	46	960
7	141	27	561	47	981
8	162	28	582	48	1002
9	183	29	603	49	1023
10	204	30	624	50	1044
11	225	31	645	51	1065
12	246	32	666	52	1086
13	267	33	687	53	1107
14	288	34	708	54	1128
15	309	35	729	55	1149
16	330	36	750		
17	351	37	771		
18	372	38	792		
19	393	39	813		
20	414	40	834		

Number of Holes	LTG20 mm.	Number of Holes	LTG20 mm.	Number of Holes	LTG20 mm.	Number of Holes	LTG20 mm.
1	20	11	280	21	540	31	800
2	46	12	306	22	566	32	826
3	72	13	332	23	592	33	852
4	98	14	358	24	618	34	878
5	124	15	384	25	644	35	904
6	150	16	410	26	670	36	930
7	176	17	436	27	696	37	956
8	202	18	462	28	722	38	982
9	228	19	488	29	748	39	1008
10	254	20	514	30	774	40	1034
11	280	21	540	31	800	41	1060
12	306	22	566	32	826	42	1086
13	332	23	592	33	852	43	1112
14	358	24	618	34	878	44	1138
15	384	25	644	35	904	45	1164

Sound

$$NC = 14 \text{ LOG } A + 84 \text{ LOG } V - 218$$

$$A = \text{Free area, Ft}^2$$

$$V = \text{Air Flow, CFM} / \text{Free Area, Ft}^2$$

NC based on 10dB room absorption.

Negative Static Pressure

$$S.P. = 1.36 (V/4005)^2$$

$$V = \text{Air Flow, CFM} / \text{Free Area, Ft}^2$$

S.P. = Static Pressure Drop, inches w.g.

Free Area

$$F.A. = \text{Number of holes} \times \begin{matrix} 0.0011 \text{ (LTG10)} \\ 0.0024 \text{ (LTG15)} \\ 0.0043 \text{ (LTG20)} \end{matrix}$$

Example Calculation of LTG10 with the neck area of 40 x 50 cm. at 400 cfm.

Number of holes : Horizontal Length 40 cm. = 25 holes

Vertical Length 50 cm. = 32 holes

Therefore, total number of holes = 25 x 32 = 800 holes

$$F.A. = 800 \times 0.0011 = 0.88 \text{ Ft}^2$$

Egg Crate Return Grille

Model : EGC



Fig.1 shows Model EGC

Product Features

Komfort Flow EGC Egg Crate Return Grille are available for air distribution, return air, and architectural application. It is made of aluminum. There are two models :-

- Counter Sunk Screw Holes (Model EGC)
- Hidden Screw Holes (Model EGC-R)

Characteristics

- High Grade Aluminum Construction
- Large Free Area Core
- Low Pressure Drop
- Low NC Level
- Ideal for Pressurized ceiling return
- Powder Coating Finishing
- Matches to Modern Interior and Modern Architecture

Material

The frame are constructed from extruded aluminum and the frame size is 1 1/4". Size of Aluminum core is 1/2" x 1/2" x 1/2"

Finishing

Komfort Flow Egg Crate Return Grilles are finished with the powder coating in white or Matt Black color.

Optional Features

- Opposed blade volume damper available in black color or natural anodized aluminum finish
- Wire mesh

Model EGC is easy to remove the core (EGC-R) for maintenance with Spring-Pin Lock



Suitable for the Laminar Flow pattern in the Cleanroom.

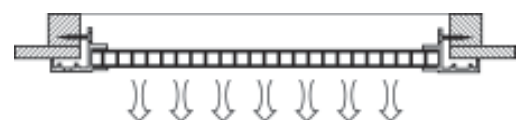

Section and Installation Details

Model : EGC

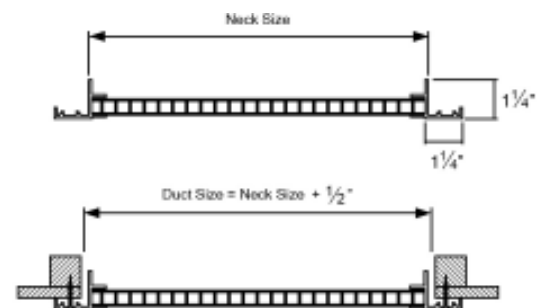

Model : EGC-R

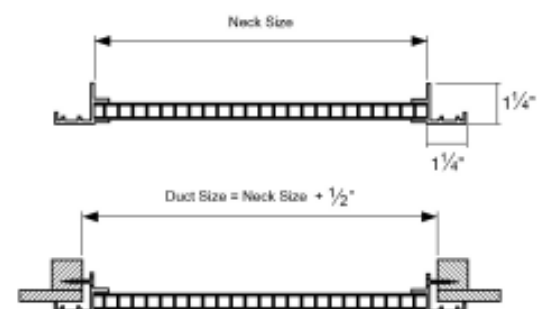

Performance Data

Core Area Sq. Feet	Duct size	Core Velocity Velocity Pressure Negative SP	300	400	500	600	700	800	NC 20		NC 30	
			0.006	0.01	0.016	0.022	0.031	0.04	1000	1200	1400	1500
			0.013	0.021	0.034	0.047	0.066	0.085	0.062	0.09	0.122	0.14
0.15	7x4	CFM	44	59	73	88	106	120	152	181	210	223
	6x5	NC	-	-	-	-	-	-	22	29	35	36
0.18	8x4 6x6	CFM	54	71	92	108	126	144	181	215	253	271
	7x5	NC	-	-	-	-	-	-	20	27	36	39
0.22	10x4 7x6	CFM	66	87	111	131	154	175	220	263	307	330
	8x5	NC	-	-	-	-	-	-	25	30	35	37
0.26	12x4 8x6	CFM	76	105	131	157	180	206	260	315	365	390
	10x5	NC	-	-	-	-	-	16	25	32	37	40
0.3	14x4	CFM	90	120	151	182	210	241	300	359	419	450
		NC	-	-	-	-	-	17	23	32	38	39
0.34	16x4 10x6	CFM	101	134	172	203	237	270	340	407	475	510
	12x5	NC	-	-	-	-	-	18	26	33	38	40
0.39	18x4 12x6	CFM	115	159	193	234	275	313	390	467	544	585
	14x5 8x8	NC	-	-	-	-	-	15	25	32	38	40
0.46	20x4 14x6	CFM	137	185	231	277	321	367	460	554	644	690
	16x5 10x8	NC	-	-	-	-	-	20	28	34	38	40
0.52	24x4 16x6	CFM	158	207	260	314	365	417	520	624	730	780
	18x5	NC	-	-	-	-	-	20	28	34	31	42
0.6	28x4 18x6 10x10	CFM	183	241	301	360	420	480	602	718	839	901
	20x5 12x8	NC	-	-	-	-	-	20	28	35	40	43
0.69	30x4 20x6 12x10	CFM	208	276	346	413	483	553	689	827	965	1037
	24x5 14x8	NC	-	-	-	-	-	20	27	33	40	44
0.81	36x4 22x6 14x10	CFM	243	322	404	487	567	649	811	973	1135	1216
	28x5 16x8	NC	-	-	-	-	-	20	29	36	42	44
0.9	40x4 26x6 16x10	CFM	271	361	449	540	541	719	899	1079	1261	1351
	30x5 18x8 12x12	NC	-	-	-	-	16	20	30	31	42	45
1.07	48x4 30x6 14x12	CFM	322	429	537	643	750	857	1069	1283	1497	1604
	36x5 18x10	NC	-	-	-	-	17	22	961	37	43	45
1.18	34x6 20x10 14x14	CFM	352	371	589	705	829	945	1181	1414	1654	1772
	24x8 16x12	NC	-	-	-	-	16	23	30	37	44	45
1.34	60x4 36x6 16x14	CFM	404	536	670	805	940	1073	1341	1610	1879	2012
	48x5 18x12	NC	-	-	-	-	19	22	33	39	45	45
1.6	72x4 24x10 18x14	CFM	482	644	802	962	1122	1281	1600	1920	2240	2400
	30x8 22x12 16x16	NC	-	-	-	-	19	23	32	38	45	47
1.8	60x5 36x8 24x12 18x16	CFM	541	721	902	1083	1261	1441	1801	2161	2521	2701
	48x6 30x10 20x14	NC	-	-	-	-	19	24	32	39	45	48
2.08	72x5 40x8 30x12 20x16	CFM	625	833	1041	1249	1457	1665	2081	2497	2913	3121
	60x6 36x10 24x14 18x18	NC	-	-	-	-	19	24	33	38	44	46
2.45	72x6 32x12 24x16	CFM	734	981	1224	1472	1717	1959	2454	2939	3431	3673
	48x8 26x14 20x18	NC	-	-	-	-	20	23	32	38	44	47
2.78	36x12 26x16 22x20	CFM	832	1111	1391	1667	1945	2223	2781	3335	3893	4171
	30x14 24x18	NC	-	-	-	-	21	23	31	39	45	46
3.11	60x8 40x12 30x16 24x20	CFM	933	1243	1556	1856	2176	2487	3000	37311	4351	4664
	48x10 36x14 26x18	NC	-	-	-	-	20	25	33	40	47	50
3.61	72x8 48x12 30x18	CFM	1083	1441	1803	2166	2527	2889	3611	4333	5053	5414
	60x10 36x16 24x24	NC	-	-	-	-	22	27	35	42	48	50
4.29	48x14 32x20	CFM	1286	1717	2144	2573	3004	3433	4290	5147	6005	6434
	36x18 28x24	NC	-	-	-	13	19	25	31	42	48	51
4.65	72x10 36x20	CFM	1395	1860	2325	2791	3256	3721	4652	5581	6511	6974
	48x16 30x24	NC	-	-	-	17	23	28	36	43	49	50
5.58	72x12 48x29	CFM	1675	2233	2791	3349	3907	4465	5581	6697	7813	8370
	60x14 36x24	NC	-	-	-	17	23	29	37	44	49	52
6.25	72x14 48x20	CFM	1876	2501	3126	3751	4376	5000	6250	7500	8752	9376
	60x16 30x30	NC	-	-	-	18	24	29	37	44	50	52

Notes:

1. All pressures are in inches of water.
2. Blanks indicate and NC level <15 dB.

NC 20 NC 30 NC 40 NC 50

Aluminum Louver **Model : AL**



Fig.1 shows Model AL

Product Features

Komfort Flow Aluminium Louver is a ventilation product that allows air to pass through it while keeping out unwanted elements such as water, dirt, and debris.

Standard blade, standard performance offers a clean appearance at a low cost.

Ideal applications include decorative, low air velocity, air exhaust, or special shape louvers.

Application of any louver involves selecting an airflow velocity through the louver free area (free area velocity in fpm) that produces an acceptable pressure drop and for intake applications minimizes carry-over of normally occurring rain.

Section Detail

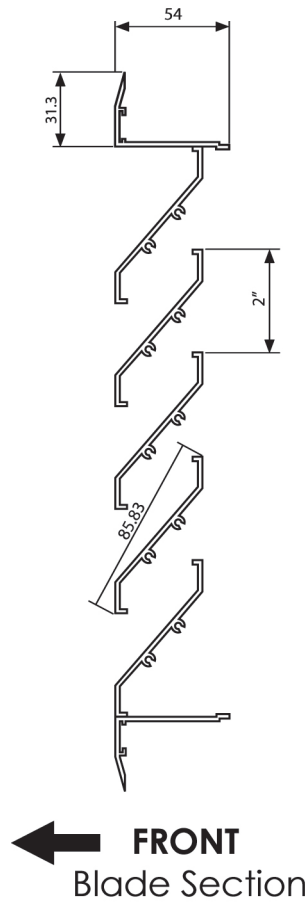

Pressure Drop - Air Intake

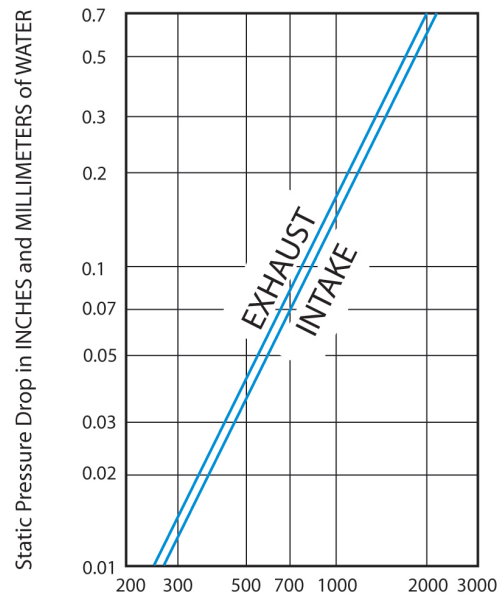

Air Velocity in FEET and METERS per minute through FREE AREA.

Free Area in Square Feet

Height (inches)	Width (inches)												
	12	18	24	30	38	42	48	54	60	66	72	84	96
12	0.364	0.559	0.754	0.949	1.157	1.313	1.521	1.716	1.911	2.106	2.314	2.678	3.068
	36%	37%	38%	38%	37%	38%	38%	38%	38%	38%	39%	38%	38%
18	0.663	1.014	1.378	1.742	2.106	2.405	2.769	3.133	3.497	3.861	4.225	4.888	5.603
	44%	45%	46%	46%	44%	46%	46%	46%	47%	47%	47%	47%	47%
24	0.871	1.352	1.833	2.314	2.795	3.198	3.679	4.16	4.641	5.122	5.603	6.487	7.436
	44%	45%	46%	46%	44%	46%	46%	46%	46%	47%	47%	46%	46%
30	1.157	1.807	2.444	3.081	3.718	4.251	4.901	5.538	6.175	6.812	7.462	8.632	9.906
	46%	48%	49%	49%	47%	49%	49%	49%	49%	50%	50%	49%	50%
38	1.404	2.184	2.964	3.744	4.511	5.161	5.941	6.721	7.501	8.268	9.048	10.478	12.025
	44%	46%	47%	47%	45%	47%	47%	47%	47%	47%	48%	47%	47%
42	1.651	2.561	3.471	4.381	5.291	6.045	6.955	7.865	8.775	9.685	10.595	12.259	14.079
	47%	49%	50%	50%	48%	49%	50%	50%	50%	50%	50%	50%	50%
48	1.95	3.016	4.095	5.161	6.24	7.137	8.203	9.282	10.348	11.427	12.506	14.469	16.614
	49%	50%	51%	52%	49%	51%	51%	52%	52%	52%	52%	52%	52%
54	2.158	3.354	4.55	5.733	6.929	7.917	9.113	10.309	11.492	12.688	13.884	16.068	18.447
	48%	50%	51%	51%	49%	50%	51%	51%	51%	51%	51%	51%	51%
60	2.444	3.796	5.148	6.5	7.852	8.983	10.335	11.687	13.039	14.391	15.73	18.213	20.917
	49%	51%	51%	52%	50%	51%	52%	52%	52%	52%	52%	52%	52%
66	2.704	4.186	5.668	7.163	8.645	9.763	11.375	12.87	14.352	15.847	17.329	20.059	23.036
	49%	51%	52%	52%	50%	51%	52%	52%	52%	52%	53%	52%	52%
72	2.938	4.563	6.175	7.8	9.425	10.764	12.389	14.014	13.026	17.251	18.876	21.84	25.077
	49%	51%	51%	52%	50%	51%	52%	52%	43%	52%	52%	52%	52%
78	3.237	5.018	6.799	8.593	10.374	11.856	13.637	15.431	17.212	18.993	20.774	24.05	27.625
	50%	51%	52%	53%	50%	52%	52%	53%	53%	53%	53%	53%	53%
84	3.445	5.356	7.254	9.152	11.063	12.649	14.547	16.328	18.356	20.254	22.165	25.649	29.328
	49%	51%	52%	52%	50%	52%	52%	52%	52%	53%	53%	52%	52%
90	3.744	5.798	7.865	9.919	11.986	13.702	15.769	17.836	19.89	21.957	24.011	27.794	31.915
	50%	52%	52%	53%	50%	52%	53%	53%	53%	53%	53%	53%	53%
96	3.991	6.188	8.385	10.582	12.779	14.612	16.809	19.019	21.216	23.413	25.61	29.64	34.034
	50%	52%	52%	53%	50%	52%	53%	53%	53%	53%	53%	53%	53%
108	4.524	7.02	9.516	12.012	14.508	16.588	19.084	21.58	24.076	26.559	29.055	33.631	38.623
	50%	52%	53%	53%	51%	53%	53%	53%	54%	54%	54%	53%	54%
120	5.031	7.8	10.569	13.351	16.12	18.434	21.203	23.972	26.754	29.523	32.292	37.375	42.926
	50%	52%	53%	53%	51%	53%	53%	53%	54%	54%	54%	53%	54%

Rain Proof Aluminum Louver Model : RAL



Fig.1 shows Model RAL

Product Features

Komfort Flow Rain Proof Aluminium Louver is an extruded aluminum stationary louver designed to protect air intake and exhaust openings in building exterior walls that are sensitive to the penetration of wind driven rain.

Design incorporates drainable head member and horizontal blades to provide maximum resistance to wind blown rain.

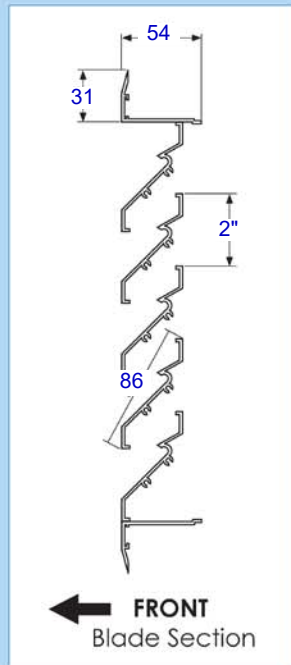

Fig.2 shows Blade Section

Application of any louver involves selecting an airflow velocity through the louver free area (free area velocity in fpm) that produces an acceptable pressure drop and for intake applications minimizes carry through of normally encountered rain water.

The point of zero water penetration is defined as that velocity where the water penetration curve projects through .01 oz. of water (penetration) per sq.ft. of louver free area.

The beginning point of water penetration for Model RAL is 514 FPM free area velocity. These performance ratings do not guarantee a louver to be weatherproof or stormproof and should be used in combination with other factors in selecting louvers (i.e. prevailing wind direction, weather patterns for the building location area, desired safety factor, etc.).

Water Penetration Throught A48" x 48" Louver for 15 Min. Test at 4"/Hr. Rainfall

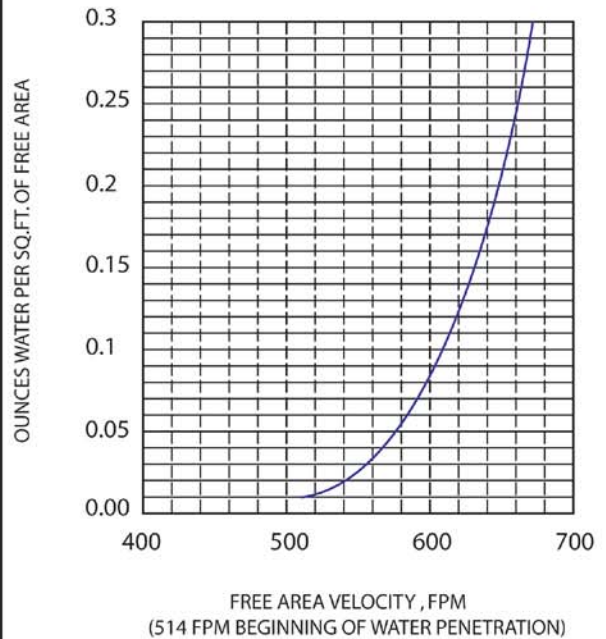

Louver Pressure Drop

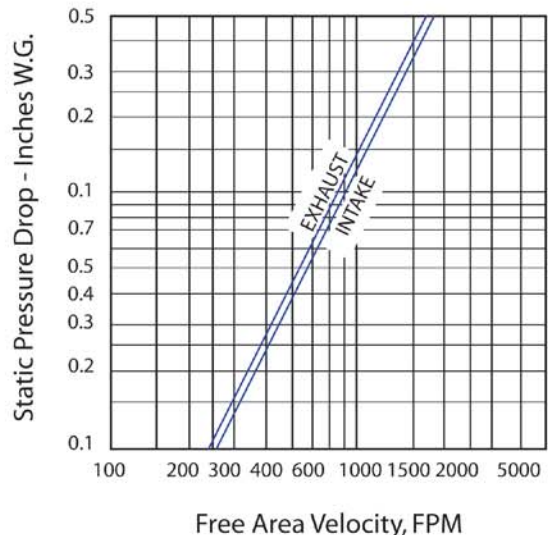

Free Area in Square Feet

Height (inches)	Width (inches)												
	12	18	24	30	38	42	48	54	60	66	72	84	96
12	0.28	0.43	0.58	0.73	0.89	1.01	1.17	1.32	1.47	1.62	1.78	2.06	2.36
	28%	29%	29%	29%	28%	29%	29%	29%	29%	29%	30%	29%	30%
18	0.51	0.78	1.06	1.34	1.62	1.85	2.13	2.41	2.69	2.97	3.25	3.76	4.31
	34%	35%	35%	36%	34%	35%	36%	36%	36%	36%	36%	36%	36%
24	0.67	1.04	1.41	1.78	2.15	2.46	2.83	3.2	3.57	3.94	4.31	4.99	5.72
	34%	35%	35%	36%	34%	35%	35%	36%	36%	36%	36%	36%	36%
30	0.89	1.39	1.88	2.37	2.86	3.27	3.77	4.26	4.75	5.24	5.74	6.64	7.62
	36%	37%	38%	38%	36%	37%	38%	38%	38%	38%	38%	38%	38%
38	1.08	1.68	2.28	2.88	3.47	3.97	4.57	5.17	5.77	6.36	6.96	8.06	9.25
	34%	35%	36%	36%	35%	36%	36%	36%	36%	37%	37%	36%	37%
42	1.27	1.97	2.67	3.37	4.07	4.65	5.35	6.05	6.75	7.45	8.15	9.43	10.83
	36%	38%	38%	39%	37%	38%	38%	38%	39%	39%	39%	38%	39%
48	1.5	2.32	3.15	3.97	4.8	5.49	6.31	7.14	7.96	8.79	9.62	11.13	12.78
	38%	39%	39%	40%	38%	39%	39%	40%	40%	40%	40%	40%	40%
54	1.66	2.58	3.5	4.41	5.33	6.09	7.01	7.93	8.84	9.76	10.68	12.36	14.19
	37%	38%	39%	39%	37%	39%	39%	39%	39%	39%	40%	39%	39%
60	1.88	2.92	3.96	5	6.04	6.91	7.95	8.99	10.03	11.07	12.1	14.01	16.09
	38%	39%	40%	40%	38%	39%	40%	40%	40%	40%	40%	40%	40%
66	2.08	3.22	4.36	5.51	6.65	7.51	8.75	9.9	11.04	12.19	13.33	15.43	17.72
	38%	39%	40%	40%	38%	39%	40%	40%	40%	40%	40%	40%	40%
72	2.26	3.51	4.75	6	7.25	8.28	9.53	10.78	10.02	13.27	14.52	16.8	19.29
	38%	39%	40%	40%	38%	39%	40%	40%	33%	40%	40%	40%	40%
78	2.49	3.86	5.23	6.61	7.98	9.12	10.49	11.87	13.24	14.61	15.98	18.5	21.25
	38%	40%	40%	41%	39%	40%	40%	41%	41%	41%	41%	41%	41%
84	2.65	4.12	5.58	7.04	8.51	9.73	11.19	12.56	14.12	15.58	17.05	19.73	22.56
	38%	39%	40%	40%	38%	40%	40%	40%	40%	40%	41%	40%	40%
90	2.88	4.46	6.05	7.63	9.22	10.54	12.13	13.72	15.3	16.89	18.47	21.38	24.55
	38%	40%	40%	41%	39%	40%	40%	41%	41%	41%	41%	41%	41%
96	3.07	4.76	6.45	8.14	9.83	11.24	12.93	14.63	16.32	18.01	19.7	22.8	26.18
	38%	40%	40%	41%	39%	40%	40%	41%	41%	41%	41%	41%	41%
108	3.48	5.4	7.32	9.24	11.16	12.76	14.68	16.6	18.52	20.43	22.35	25.87	29.71
	39%	40%	41%	41%	39%	41%	41%	41%	41%	41%	41%	41%	41%
120	3.87	6	8.13	10.27	12.4	14.18	16.31	18.44	20.58	22.71	24.84	28.75	33.02
	39%	40%	41%	41%	39%	41%	41%	41%	41%	41%	41%	41%	41%

Galvanized Steel Duct Damper **Model : VD**



Fig.1 shows Model VD

Product Features

A basic no-frills industrial Triple-V Groove Damper, Model VD is a ruggedly built, solid performer in Komfort Flow's line of heavy duty control dampers.

Material

The frame size is 8" deep x 1-3/8" x 18 gage (200 x 35 x 1.2 mm.) galvanized steel channel. Blades is triple-V groove, 18 gage (1.2 mm) galvanized steel. Axles shall be 10 mm plated steel rod. The axles shall be an integral part of the damper linkage attaching directly to the tie bar. Bearings is brass.

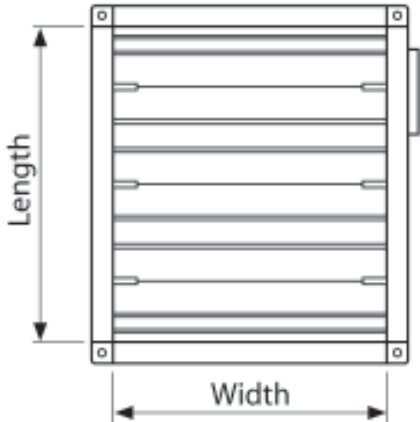

Parallel Blade Damper Type

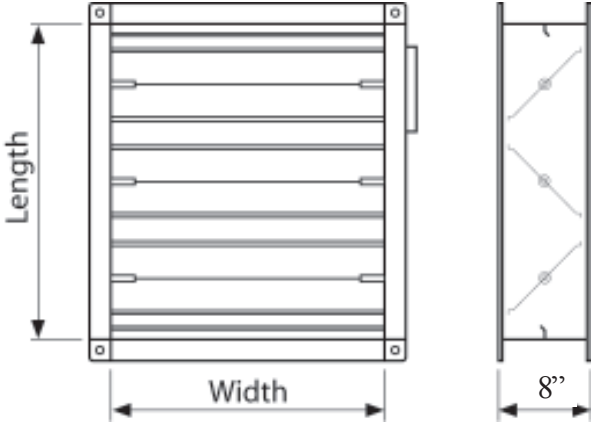

Opposed Blade Damper Type

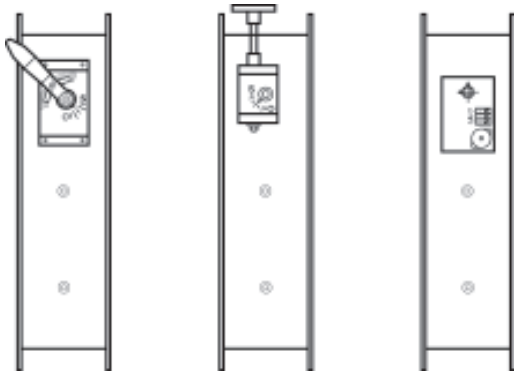

Lever Hand Gear Motorized

Komfort Flow Duct Damper offer the selection of

- Parallel Blade Damper (called "Model VD Parallel")
- Opposed Blade Damper (called "Model VD")

With the three options of Adjust equipment as follows

- Hand Gear (called "Model VD-G")
- Lever (called "Model VD")
- Motorized (called "Model VD-M")

Air Filter

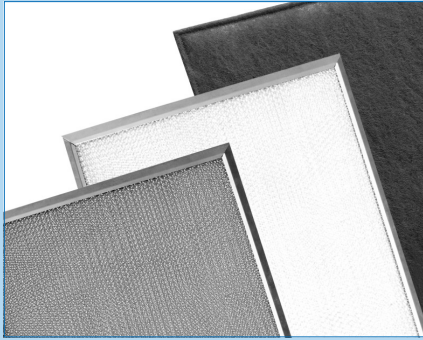

Fig.1 shows all kinds of Air Filter

Product Features

Filters are primarily used to remove particles from the air. The type and design of filter determine the efficiency at removing particles of a given size and the amount of energy needed to pull or push air through the filter.

Filters are rated by different standards and test methods such as dust spot and arrestance which measured different aspects of performance.

Our company offers three main selection of Komfort Flow Air Filter : Aluminium Filter, Synthetic Filter and Nylon Filter.

Aluminium

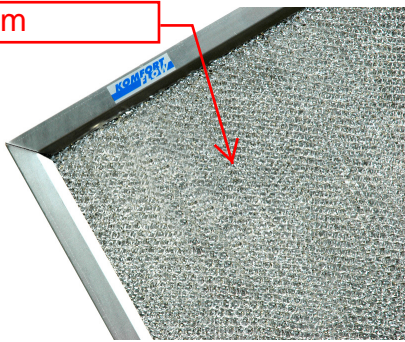

ALUMINIUM FILTER

Komfort Flow Aluminium Filter is made from several layer of Expanded Aluminium Sheets. This can filter dirt, dust, oil .

Velocity (FPM) Resistance (W.G.)

300	0.05
350	0.06
400	0.08
450	0.10
500	0.13

Material : Aluminium Sheets
 Washable : YES
 Standard : 1.5" - 2"
 Thickness
Special size is upon request.

ใยขาว ขอบอลูฯ



SYNTHETIC FILTER - AIR FILTER MEDIA - White Color

Prefilters for high dust concentrations. Air ventilation and air conditioning plants with low requirements for air quality.

Technical Data

Nominal air volume	5400 m ³ /h/m ²
Average dust weight arrestance	82 %
Average dust spot efficiency	- %
Initial pressure drop	19 Pa
Recommended final pressure drop	160 Pa
Temp. resistance Max.	120 °C

Material : Synthetic
 Washable : YES
 Standard : 1.5" - 2"
 Thickness
Special size is upon request.

ใยดำ ขอบลวด

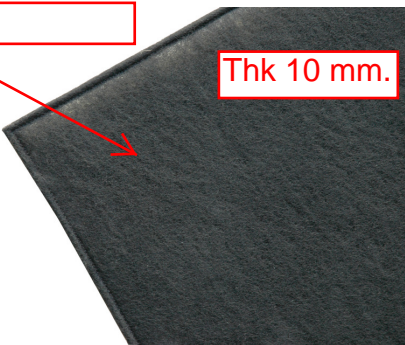

SYNTHETIC FILTER - AIR FILTER MEDIA - Black Color

Prefilters for high dust concentrations. Air ventilation and air conditioning plants with low requirements for air quality. Material is synthetic fiber in Black Color, Size and Thickness as customer's order.

Technical Data

Nominal air volume	5400 m ³ /h/m ²
Average dust weight arrestance	82 %
Average dust spot efficiency	- %
Initial pressure drop	19 Pa
Recommended final pressure drop	160 Pa
Temp. resistance Max.	130 °C

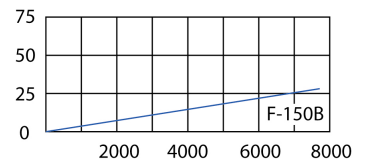

ไนลอนดำ ขอบลวด

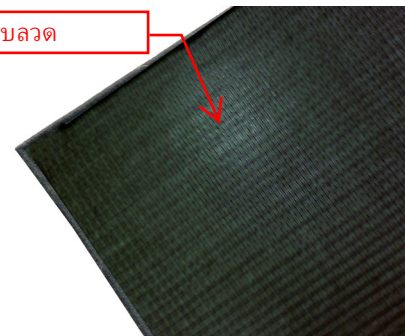

NYLON FILTER

Komfort Flow Nylon Filter can filter dust in long time due to durable and strong plastic net. It comes in many small square-shape holes originate good ventilation. This type of filter is Easy to clean by using brush

Technical Data

Average synthetic dust weight arrestance	80 %
Initial pressure drop	23 Pa
Recommended final pressure drop	120 Pa
Maximum Ambient Temperature	100 °C
Material	PP Thread Size 0.20-0.21 mm.

Jet Diffuser

Model : JD



Fig.1 shows Model JD

Product Features

Jet nozzles are used for preference where the supply air from the diffuser has to travel a large distance to the occupied zone. This is the case in large rooms (halls, assembly rooms etc.), particularly when the distribution of air via ceiling diffusers is not possible or not practical. Here jet diffusers are arranged in the side wall areas. The direction of the air stream from the type jet nozzle can be easily adjusted manually to suit particular on site conditions. Also the pivoting movement can be adjusted within the range of +/- 30 degree.

Material and Finishing

The frame and adjustable nozzle made from aluminum and finishing with the powder coating, (Standard Color in White)

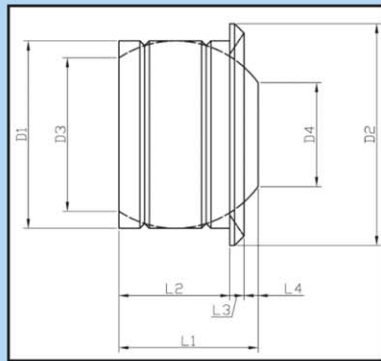

Fig.2 Section Detail

Size	D1	D2	D3	D4	L1	L2	L3	L4
6"	148	200	105	78	110	85	22	3
8"	198	265	145	110	140	105	25	10
10"	248	315	195	130	180	135	30	15
12.6"	315	390	250	168	230	170	30	30
14"	348	430	275	185	250	190	33	27
16"	398	495	320	210	280	218	35	27
18"	448	560	355	237	315	235	35	45
20"	498	615	400	255	350	255	45	50

Performance Data

SIZE	Duct Velocity (FPM)	200	300	400	500	600	700	800
	Velocity Pres (IN WG)	0.002	0.006	0.01	0.016	0.022	0.031	0.04
6"	Flow Rate (CFM)	135	203	271	339	406	474	542
	Total Pressur (IN WG)	0.076	0.171	0.303	0.474	0.683	0.929	1.214
	Static Pressu (IN WG)	0.074	0.165	0.293	0.458	0.661	0.898	1.174
	NC Level	-	19	28	35	40	45	50
	Throw (FT)	15	17	20	23	25	27	29
8"	Flow Rate (CFM)	196	294	392	490	588	685	783
	Total Pressur (IN WG)	0.056	0.127	0.226	0.353	0.508	0.691	0.903
	Static Pressu (IN WG)	0.054	0.121	0.216	0.337	0.486	0.66	0.863
	NC Level	-	17	25	31	36	40	44
	Throw (FT)	17	21	25	27	30	32	34
10"	Flow Rate (CFM)	267	401	535	668	802	936	1070
	Total Pressur (IN WG)	0.037	0.084	0.149	0.232	0.334	0.455	0.594
	Static Pressu (IN WG)	0.035	0.078	0.139	0.216	0.312	0.424	0.554
	NC Level	-	-	18	25	30	35	39
	Throw (FT)	20	25	29	32	35	38	41
12"	Flow Rate (CFM)	350	525	700	875	1050	1225	1400
	Total Pressur (IN WG)	0.033	0.075	0.132	0.207	0.298	0.406	0.53
	Static Pressu (IN WG)	0.031	0.069	0.122	0.191	0.276	0.375	0.49
	NC Level	-	11	16	26	31	35	39
	Throw (FT)	23	28	33	36	40	43	47
14"	Flow Rate (CFM)	444	666	888	1109	1331	1553	1775
	Total Pressur (IN WG)	0.024	0.055	0.097	0.125	0.219	0.299	0.39
	Static Pressu (IN WG)	0.022	0.049	0.087	0.109	0.197	0.268	0.35
	NC Level	-	12	20	26	31	36	39
	Throw (FT)	26	32	37	41	45	49	53
16"	Flow Rate (CFM)	548	823	1097	1371	1645	1919	2194
	Total Pressur (IN WG)	0.022	0.052	0.092	0.118	0.215	0.293	0.362
	Static Pressu (IN WG)	0.020	0.046	0.082	0.102	0.193	0.262	0.322
	NC Level	-	11	17	28	33	36	40
	Throw (FT)	29	35	40	44	48	52	55
18"	Flow Rate (CFM)	665	997	1329	1662	1994	2326	2658
	Total Pressur (IN WG)	0.022	0.051	0.090	0.114	0.211	0.292	0.359
	Static Pressu (IN WG)	0.020	0.045	0.080	0.098	0.189	0.261	0.319
	NC Level	-	12	18	30	34	37	41
	Throw (FT)	30	38	42	48	50	54	59
20"	Flow Rate (CFM)	792	1187	1583	1979	2375	2771	3166
	Total Pressur (IN WG)	0.021	0.050	0.088	0.113	0.209	0.291	0.357
	Static Pressu (IN WG)	0.019	0.044	0.078	0.097	0.187	0.260	0.317
	NC Level	-	12	20	32	35	40	42
	Throw (FT)	32	40	45	51	54	56	62

JET DIFFUSER

MODEL : JD-A

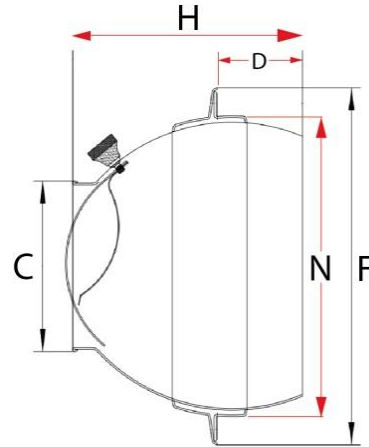

Size	Actual Neck Size (N)	C	H	D	F
150	140	82	110	32	195
200	200	115	160	48	260
250	240	147	182	43	300
315	305	173	250	80	366

Size(in)	Velocity	FPM	400	600	800	1000	1200	1400	1600	2000
6 A= 0.057	Flow Rate	CFM	65	97	129	162	194	226	259	323
	Static Pressure	in.wg.	0.008	0.020	0.036	0.052	0.076	0.104	0.136	0.213
	Throw	Ft.	5	7	10	12	15	17	20	25
8 A= 0.112	Flow Rate	CFM	127	191	254	318	381	445	508	636
	Static Pressure	in.wg.	0.012	0.024	0.044	0.068	0.096	0.128	0.169	0.265
	Throw	Ft.	7	11	14	18	22	26	29	36
10 A= 0.183	Flow Rate	CFM	208	312	415	519	623	727	831	1,039
	Static Pressure	in.wg.	0.012	0.024	0.048	0.072	0.104	0.141	0.185	0.289
	Throw	Ft.	9	14	18	23	28	32	37	46
12 A= 0.253	Flow Rate	CFM	288	432	575	719	863	1,007	1,151	1,438
	Static Pressure	in.wg.	0.012	0.028	0.048	0.080	0.112	0.153	0.201	0.313
	Throw	Ft.	11	16	22	27	33	38	44	55

A = Area of Outlet (Sq.ft.)

Round Flat Plate Diffuser **Model : RD-F**



Fig.1 shows Model RD-F

Product Features

Komfort Flow Round Flat Plate Diffuser are available for the air distribution, return air, and architectural application. Center core can be adjusted up and down to suit the required application.

Characteristics

- High Grade Aluminum Construction
- Low Pressure Drop
- Low NC Level
- Ideal for exposed ceiling
- Powder Coating Finishing
- Matches to Modern Interior and Modern Architecture
- Easy for adjusting and cleaning

Material

The frame and core are constructed from cold formed aluminum. All steel fixings are gvanized plated.

Finishing

Komfort Flow Round Flat Plate Diffuser are finished with the powder coating in standard white color (other colors upon request)

Optional Features

- Round butterfly volume damper made of gvanized steel is available in black color.

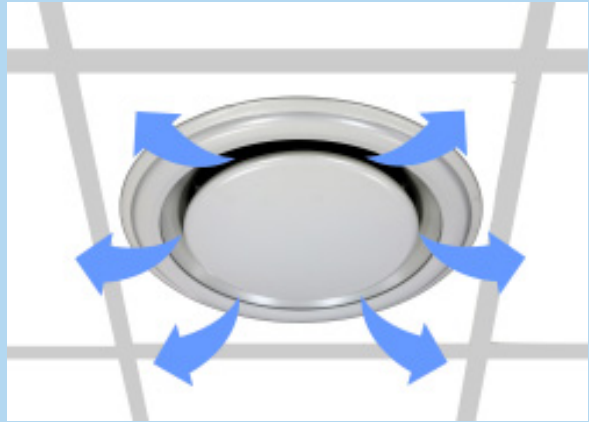

Air Pattern

Round Flat Diffuser will create air discharge 360 degree flow direction.

Section Details

Model : RD-F

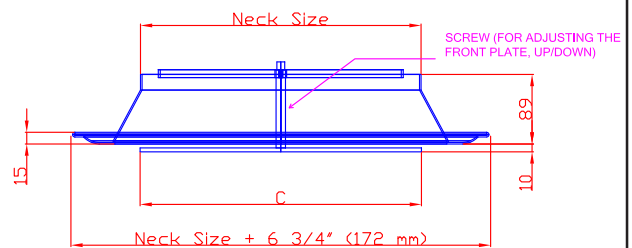

Size (in)	Neck Size (mm)	C (mm)
6	153	163
8	207	217
10	257	267
12	308	318
14	359	369
16	410	420
18	460	470
20	511	521

Round Louver (Pipe Hood) Model : RL

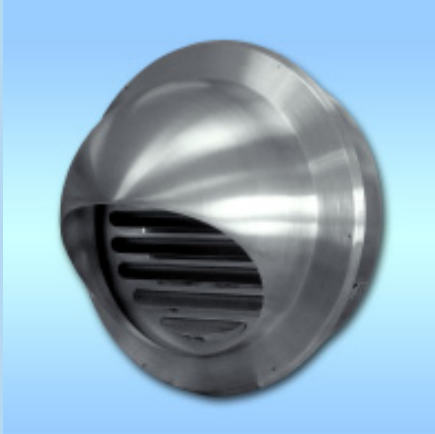

Fig.1 shows Model RL

Product Features

Round Louver or Pipe Hood are used as exhaust or fresh air ventilation. It has louver blade, insect screen inside and rain hood for protecting the weather. Easy installation with round neck and clip. Available size in 4", 6", 8", 10", 12".

Material and Finishing

High strength stainless steel.

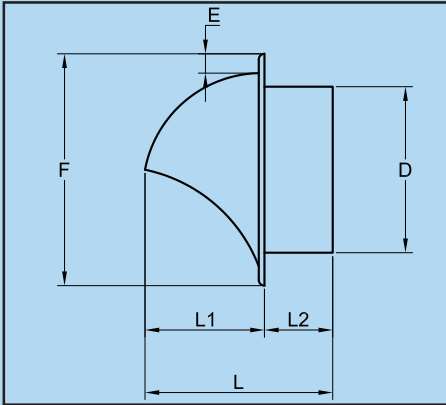

Fig.2 Section Detail

Size	D	F	L	L2	L1	E
100 4"	95 3 3/4"	145	110	40	70	13
150 6"	146 5 3/4"	204	165	60	105	17
200 8"	197 7 3/4"	225	150	50	100	28
250 10"	248 9 3/4"	340	190	55	135	22
300 12"	298 11 3/4"	340	200	80	120	22

Round Louver **Model : RL**



Product Features

Round Louver are used as exhaust or fresh air ventilation. It has louver blade, insect screen inside. Easy installation with round neck and clip. Available size in 4" and 6".

Material and Finishing

High strength stainless steel.

Fig.1 shows Model RL

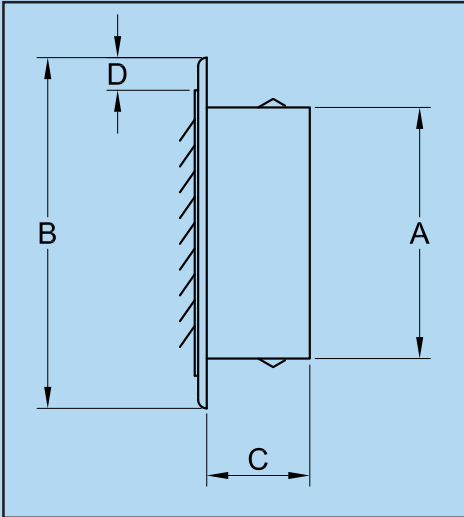

Size	A	B	C	D
100 4"	95 3 3/4"	145	42	5
150 6"	146 5 3/4"	204	62	5



Fig.2 Section Detail